

# HUSSMANN®



## ***HGL- 1, 2 & 3 BS, TS***

***Bottom / Top Mount  
Low Temperature  
Remote and Self Contained  
Glass Door Merchandisers***



**HGL-2BS**



**HGL-3TS**

***Installation &  
Service Manual***

**IMPORTANT**  
Keep in store for future reference!

**P/N 0515296\_A**

January 2011





# ATTENTION

Merchandiser must operate for 24 hours  
before loading product!

Regularly check merchandiser temperatures.

Do not break the cold chain. Keep products  
in cooler before loading into merchandiser.

These merchandisers are designed  
for pre-frozen products only.



IMPORTANT  
KEEP IN STORE FOR FUTURE REFERENCE  
*Quality that sets industry standards!*

**HUSSMANN**®

12999 St. Charles Rock Road • Bridgeton, MO 63044-2483

U.S. & Canada 1-800-922-1919 • Mexico 1-800-522-1900

[www.husmann.com](http://www.husmann.com)

© 2011 Hussmann Corporation



**ANSI DEFINITIONS** ..... vi

**INSTALLATION**

Certification ..... 1-1  
 Hussmann Product Control ..... 1-1  
 Shipping Damage ..... 1-1  
 Location ..... 1-1  
 Self Contained Location ..... 1-2  
 Model Description ..... 1-4  
 Unloading ..... 1-4  
 Exterior Loading ..... 1-4  
 Shipping Skid ..... 1-4  
 Merchandiser Leveling ..... 1-5  
 Leg Installation (Top Mounts Only) ..... 1-5  
 Serial Plate Location ..... 1-5  
 Refrigeration Unit Access ..... 1-6  
 Sealing Merchandiser to Floor ..... 1-6  
 Air Distribution & Rear Flue Spacer .... 1-6  
 Shelves ..... 1-6

**ELECTRICAL / REFRIGERATION**

Merchandiser Electrical Data ..... 2-1  
 Field Wiring ..... 2-1  
 Electrical Connections ..... 2-1  
 Electrical Enclosure ..... 2-1  
 Power Switches ..... 2-1  
 Electrical Outlet ..... 2-1  
 Refrigeration (Self Contained) ..... 2-2  
 Refrigeration (Remote) ..... 2-2  
 Line Sizing (Remote) ..... 2-2  
 Koolgas (Remote) ..... 2-2  
 Compressor ..... 2-3  
 Condensate Pan ..... 2-3  
 Shelves ..... 2-3  
 Air Distribution and Rear Flue Spacer .. 2-3  
 NOTES: ..... 2-4

**START UP / OPERATION**

Safe-NET III User Instructions ..... 3-1  
 User Instructions ..... 3-1  
 Display ..... 3-2  
 Start-Up ..... 3-2  
 Sequence of Operation Diagram ..... 3-4  
 Alarms and Codes ..... 3-5  
 Defrost Termination Switch ..... 3-5  
 Manual Defrost ..... 3-5  
 Temperature Adjustment ..... 3-6  
 Sensor to Control Adjustment ..... 3-7  
 Controls and Adjustments ..... 3-8  
 Start Up ..... 3-9  
 Crankcase Pressure Regulator ..... 3-9  
 Receiver ..... 3-9  
 TEV Adjustment ..... 3-10  
 Load Limits ..... 3-11  
 Stocking ..... 3-11  
 Thermometer ..... 3-12  
 Lighting ..... 3-12  
 Door Switches ..... 3-12  
 Door Defrost Heater Thermostat ..... 3-12  
 Alarm Thermostat ..... 3-12

**MAINTENANCE**

Care and Cleaning ..... 4-1  
 Do NOT Use: ..... 4-1  
 Do: ..... 4-1  
 Cleaning Stainless Steel Surfaces ..... 4-2  
 Cleaning Coils ..... 4-2  
 Cleaning Evaporation Pan ..... 4-3  
 NOTES: ..... 4-4

**SERVICE**

Replacing Fan Motors and Blades ..... 5-1  
 Replacing Thermometer ..... 5-1  
 Defrost Heater Replacement ..... 5-1  
 Troubleshooting Guide ..... 5-2  
 Lighting Problem / Solution ..... 5-4

**APPENDIX**

Part Numbers ..... A-1  
HGL-1BS — Plan View ..... A-3  
HGL-2BS & HGL-3BS — Plan View ... A-4  
HGL-1TS — Plan View ..... A-5  
HGL-2TS & HGL-3TS — Plan View ... A-6  
HGL Dimensions & Electrical Data .... A-7  
Cross Sections and Refrigeration Data .. A-8  
HGL Remote Wiring Diagram ..... A-9  
HGL Self-Contained Wiring Diagram .. A-10

**REVISION HISTORY**

**ORIGINAL ISSUE — JANUARY 2011**

\*\*\*\*\*

**ANSI Z535.5 DEFINITIONS**



• **DANGER** – Indicate[s] a hazardous situation which, if not avoided, will result in death or serious injury.



• **WARNING** – Indicate[s] a hazardous situation which, if not avoided, could result in death or serious injury.



• **CAUTION** – Indicate[s] a hazardous situation which, if not avoided, could result in minor or moderate injury.

• **NOTICE** – *Not related to personal injury* – Indicates[s] situations, which if not avoided, could result in damage to equipment.

## INSTALLATION

### CERTIFICATION

These merchandisers are manufactured to meet ANSI / National Sanitation Foundation (NSF®) Standard #7 requirements. Proper installation is required to maintain certification. Near the serial plate, each case carries a label identifying the type of application for which the case was certified.

**ANSI/NSF-7 Type I - Display Refrigerator / Freezer**  
**Intended for 75°F / 55% RH Ambient Application**

**ANSI/NSF-7 Type II - Display Refrigerator / Freezer**  
**Intended for 80°F / 55% RH Ambient Application**

**ANSI/NSF-7 - Display Refrigerator**  
**Intended for Bulk Produce**

### HUSSMANN PRODUCT CONTROL

The serial number and shipping date of all equipment is recorded in Hussmann's files for warranty and replacement part purposes. All correspondence pertaining to warranty or parts ordering must include the serial number of each piece of equipment involved. This is to ensure the customer is provided with the correct parts.

### SHIPPING DAMAGE

All equipment should be thoroughly examined for shipping damage before and during unloading. This equipment has been carefully inspected at our factory. Any claim for loss or damage must be made to the carrier. The carrier will provide any necessary inspection reports and/or claim forms.

### Apparent Loss or Damage

If there is an obvious loss or damage, it must be noted on the freight bill or express receipt and signed by the carrier's agent; otherwise, carrier may refuse claim.

### Concealed Loss or Damage

When loss or damage is not apparent until after equipment is uncrated, retain all packing materials and submit a written response to the carrier for inspection within 15 days.

### LOCATION

These merchandisers are designed for displaying products in air conditioned stores where temperature is maintained at or below the ANSI / NSF-7 specified level and relative humidity is maintained at or below 55%.

**Recommended operating ambient  
 temperature is between  
 65°F (18°C) and 75°F (23.9°C).  
 Maximum relative humidity is 55%.**

Placing refrigerated merchandisers in direct sunlight, near hot tables or near other heat sources could impair their efficiency. Like other merchandisers, these merchandisers are sensitive to air disturbances. Air currents passing around merchandisers will seriously impair their operation. Do NOT allow air conditioning, electric fans, open doors or windows, etc. to create air currents around the merchandiser.

## 1-2 INSTALLATION

### SELF CONTAINED (LOCATION)

Product should always be maintained at proper temperature. This means that from the time the product is received, through storage, preparation and display, the temperature of the product must be controlled to maximize the life of the product.

BE SURE TO POSITION SELF CONTAINED MERCHANDISERS PROPERLY.

### HGL-TS Location

The condensing unit is located at the top of the HGL-TS. **At least 12 inches of clearance should be allowed at the rear of the cabinet and at the top of the merchandiser.** This clearance is necessary to provide free air movement to and from the condenser for maximum operating efficiency.

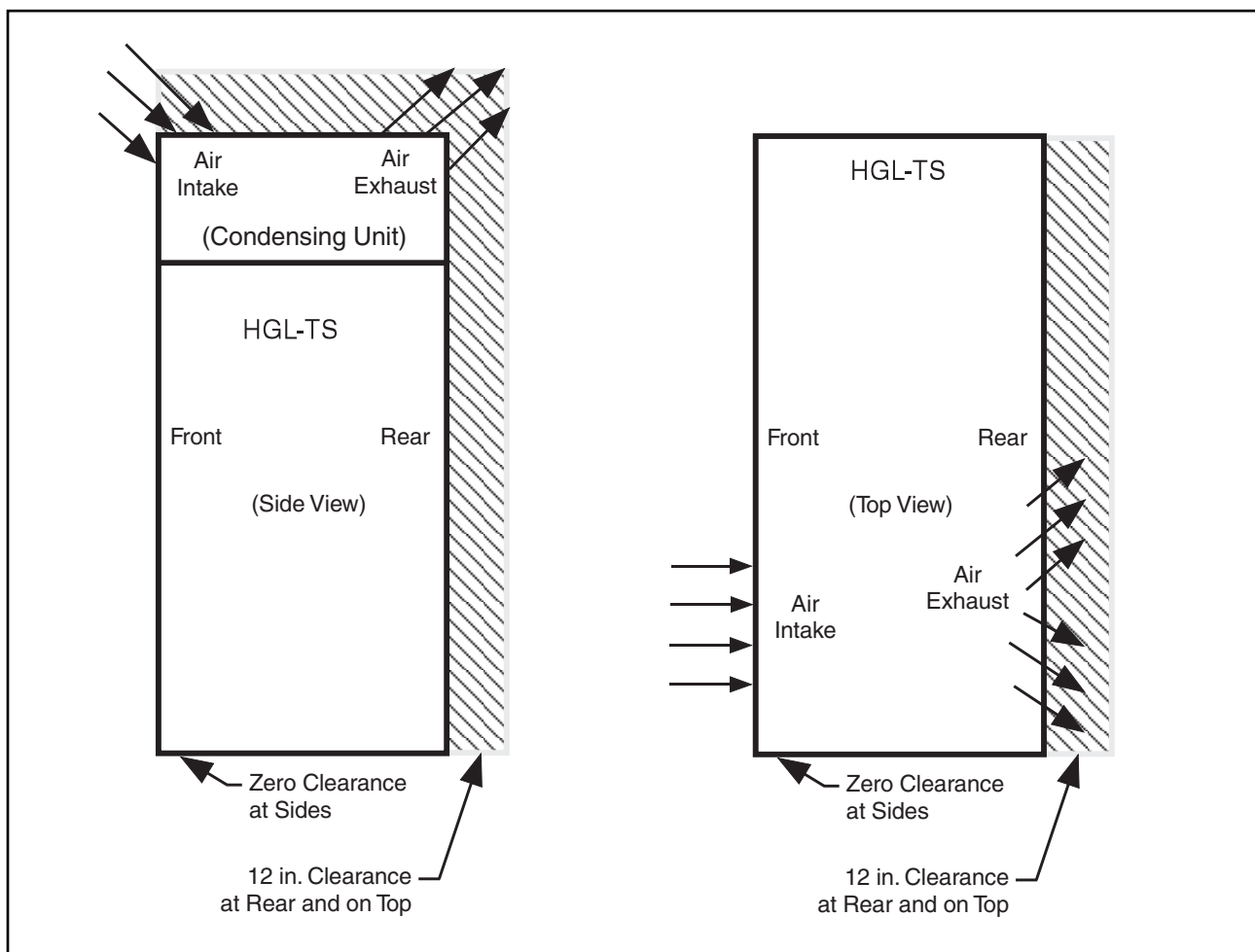

### HGL-BS Location

At least 24 inches of clearance should be maintained in front of HGL-BS merchandisers and 6 inches of clearance at the rear to provide the necessary free air movement to and from the condenser. The condensing unit is located at the bottom of these merchandisers.

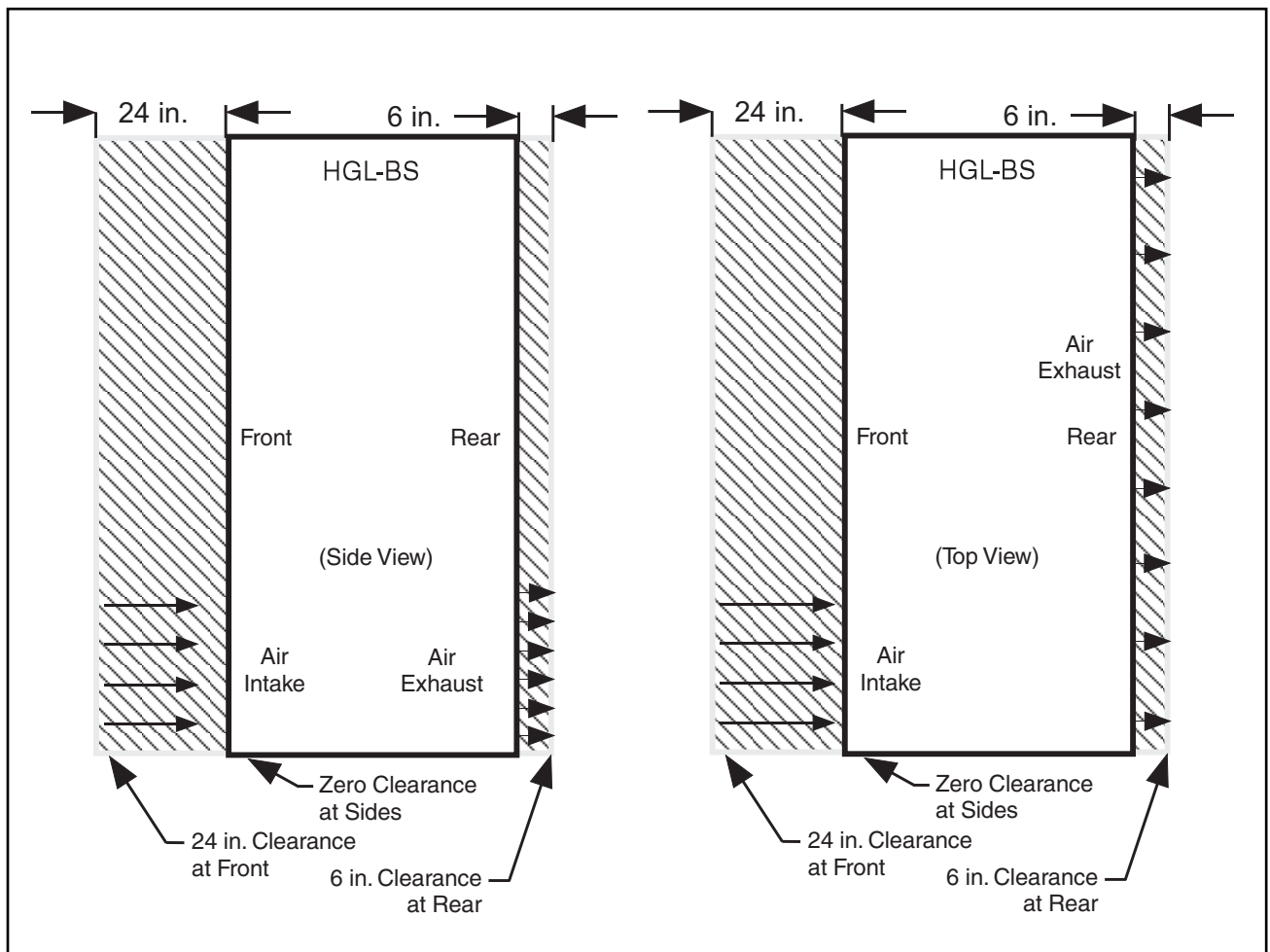

## MODEL DESCRIPTION

Hussmann HGL-TS/BS models are self-contained, low temperature, vertical display merchandisers designed for ice cream and frozen foods. Design features include: heated glass doors for fog-free visibility, automatic defrost, efficient foamed in place non-CFC insulation, cord connection for self-contained 208-230 volt application, and balanced refrigeration systems for energy-saving performance.



## CAUTION

Do not walk or put heavy objects on case.

## UNLOADING

### Unloading from Trailer:

Lever Bar (also known as a Mule, Johnson Bar, J-bar, Lever Dolly, or Pry Lever)

Move the merchandiser as close as possible to its permanent location and remove all packaging. Check for damage before discarding packaging. Remove all separately packed accessories such as kits and shelves.

Improper handling may cause damage to the merchandiser when unloading. To avoid damage:

1. Do not drag the merchandiser out of the trailer. Use a Johnson bar (mule).
2. Use a forklift or dolly to remove the merchandiser from the trailer.

## EXTERIOR LOADING

**Do NOT walk on top of merchandisers** or damage to the merchandisers and serious personal injury could occur.

MERCHANDISERS ARE NOT STRUCTURALLY DESIGNED TO SUPPORT EXTERNAL LOADING such as the weight of a person. Do not place heavy objects on the merchandiser.

## SHIPPING SKID

Each merchandiser is shipped on a skid to protect the merchandiser's base, and to make positioning the case easier.

Remove the top of the crate and detach walls from each other. Lift crate from the skid. Unscrew the case from the skid. The fixture can now be lifted off the crate skid. **Lift only at base of skid!** Remove any braces and/or skids attached (blanket wrapped merchandiser may have skids).

## DO NOT LAY MERCHANDISER OVER ON THE FLOOR TO REMOVE SKID.

Once the skid is removed, the merchandiser must be lifted —NOT PUSHED— to reposition. To remove the skid, remove screws attaching skid to the merchandiser.

Check floor where cases are to be set to see if it is a level area. Determine the highest part of the floor.



## WARNING

**Do NOT remove shipping crate until the merchandiser is positioned for installation.**

### MERCHANDISER LEVELING

BE SURE TO POSITION MERCHANDISERS PROPERLY. Level the merchandiser at corners.

Merchandiser(s) must be installed level to ensure proper operation of the refrigeration system and to ensure proper drainage of defrost water. The merchandiser can be leveled by shimming under the cabinet base frame, or by installing optional leg levelers.

The self-closing doors require the cabinet to be properly leveled. End to end leveling will allow the door(s) to close with uniform speed and tightness. A slight pitch from front to rear is desirable. **THE BACK OF MERCHANDISER SHOULD NEVER BE HIGHER THAN THE FRONT.**

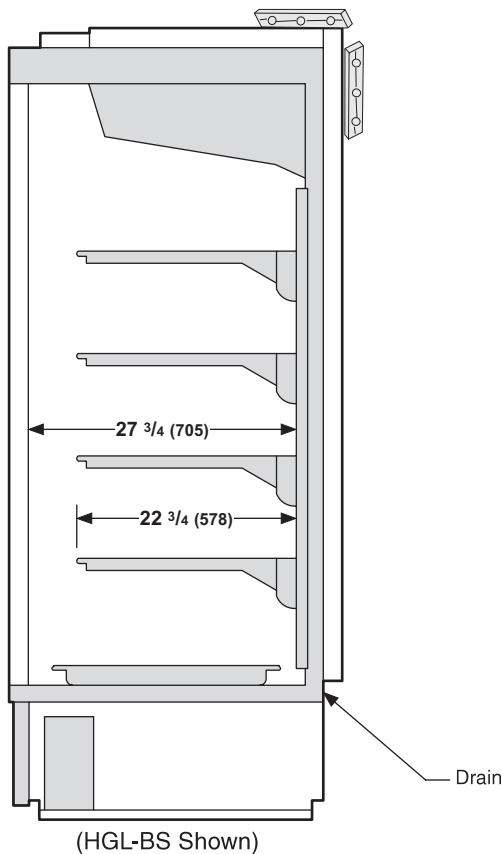

### LEG INSTALLATION (Top Mounts Only)

Install the NSF approved legs after the case is near its final location. The legs are packaged inside the cabinet. Replace the tape and door blocks.

To install legs:

Raise one end of the cabinet about 8 inches. Block the merchandiser securely, and install two legs. The leg mounting plates are factory installed and contain a 1/2 x 13 in. tapped hole to mate with the leg assembly. The procedure is repeated on the opposite end. Three-door merchandisers require legs in the center.

The cabinet should now be positioned at its final location with all legs installed. The merchandiser is leveled by turning the bottom section of each leg. End to end leveling will make the door(s) close with uniform speed and tightness. A slight pitch from front to rear is desirable.

### SERIAL PLATE LOCATION

The serial plate is located in the upper left-hand corner of the merchandiser's interior. The serial plate contains all pertinent information such as model, serial number, amperage rating, refrigerant type and charge. **Do not remove the serial plate under any circumstance.**



## REFRIGERATION UNIT ACCESS

**Top Mounts** — The top decorative panel is removed by lifting the panel up and pulling forward.

**Bottom Mounts** — The lower front panel may be removed by removing screw at bottom and lifting the panel straight upward and over the tabs on which it is hanging. The panel is installed by reversing the above procedure.

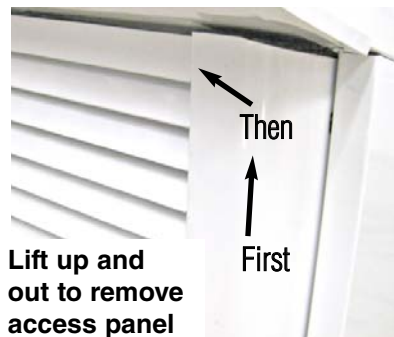

Ensure lower front panel is flat against the floor when installed to prevent air circulation problems for self contained merchandisers. If the condensing unit needs to be serviced, it can be pulled out to gain access for hard to reach components like the condenser fans. To pull out the condensing unit, remove the two hold down brackets, at the unit base.

Care must be given to the drain line when re-inserting the condensing unit back into the case. The drain line must be inside the defrost water evaporation pan to prevent the discharge of water on the floor.

### SEALING MERCHANDISER TO FLOOR (Bottom Mounts Only)

If required by local sanitary codes, or if the customer desires, merchandisers may be sealed to the floor using a vinyl cove base trim. The size needed will depend on how much variation there is in the floor, from one end of the merchandiser to the other. Sealing of the lower

front and rear panels on self contained models may hamper their removal for servicing or maintenance of the condensing unit.

**NOTE:** Do not allow trim to cover any intake or discharge grilles located in the lower front panel.

### AIR DISTRIBUTION & REAR FLUE SPACER

Air is drawn through the evaporator from front to rear and is discharged down the back wall, returning up the face of the glass door to the return air grille.

**NOTE:** Rear flue spacer must be in place as this forms a discharge air flue at the back of the cabinet.

### SHELVES

Each cabinet is provided with four cantilever shelves per door that are adjustable by 1 inch increments. The shelves can also be tilted. Each cabinet had one bottom shelf per door. These shelves have one-inch legs to allow proper air flow in the cabinet. Behind the shelves are wire flues spacers, which allow for proper air flow. All shelves and flue spacers are white and epoxy coated for durability and ease of cleaning.

Shelves should be adjusted to desired operating height. Do not load product so that it touches the evaporator coil cover. Do not extend product past the front edge of the shelf. Extending past the edge will seriously affect internal air flow through the cabinet.

Shelves are UL rated for a maximum load of 120 lbs. **DO NOT OVERLOAD THE SHELVES.**

## ELECTRICAL / REFRIGERATION

### MERCHANDISER ELECTRICAL DATA

Refer to Appendix A of this manual or the merchandiser's serial plate for electrical information.

### FIELD WIRING

Field wiring must be sized for component amperes stamped on the serial plate. Actual ampere draw may be less than specified.

**ALWAYS CHECK THE SERIAL PLATE FOR COMPONENT AMPERES**

### ELECTRICAL CONNECTIONS

All wiring must be in compliance with NEC and local codes. All electrical connections (*for remote models*) are to be made in the electrical *Handy Box* located behind the removable base panel at the left end of the merchandiser when facing the discharge air louver.

### ELECTRICAL ENCLOSURE

Remove the access panel and electrical box cover to access the electrical enclosure. The cabinet supply breakers should be disconnected before removing the enclosure cover.

### POWER SWITCHES

The power switch is located at the electrical box, which is behind the top decorative panel (TS models) or bottom louvered panel (BS models). The switch will shut off all power to the merchandiser.

Before any service is performed on this piece of equipment, make sure the power supply to the merchandiser is disconnected.

### ELECTRICAL OUTLET:

Before the merchandiser is connected to any wall circuit, use a voltmeter to check that the outlet is at 100% of the rated voltage. The wall circuit must be dedicated for the merchandiser. Failure to do so voids the warranty. Do not use an extension cord. Never plug in more than one merchandiser per electrical circuit.

- Always use a dedicated circuit with the amperage stated on the unit.
- Plug into an outlet designed for the plug.
- Do not overload the circuit
- Do not use long or thin extension cords. Never use adapters.
- If in doubt, call an electrician.



## CAUTION

**Risk of Electric Shock. If cord or plug becomes damaged, replace only with a cord and plug of the same type.**



## WARNING

**— LOCK OUT / TAG OUT —**

***To avoid serious injury or death from electrical shock, always disconnect the electrical power at the main disconnect when servicing or replacing any electrical component. This includes, but is not limited to, such items as doors, lights, fans, heaters, and thermostats.***

Self-contained models have factory-installed power cords attached at the electrical box.

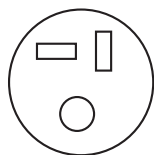

NEMA 6-20P  
Receptacle  
HGL-3 BS/TS

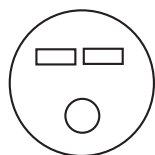

NEMA 6-15P  
Receptacle  
HGL-1,-2 BS/TS



## WARNING

**Merchandiser must be grounded.  
Do not remove the power supply cord ground.**

### REFRIGERATION (Self Contained Models)

Each self contained model is equipped with its own condensing unit. The correct type of refrigerant will be stamped on each merchandiser's serial plate. The merchandiser refrigeration piping is leak tested. The unit is charged with refrigerant, and shipped from the factory with all service valves open.

### REFRIGERATION (Remote Models)

Refrigeration temperature is controlled by an electronic factory-installed thermostat. The electronic thermostat controls a liquid line solenoid valve (not provided with the merchandiser).

The thermostat energizes the valve as the temperature rises. A pump down system is recommended for outdoor condensing units.

### LINE SIZING (Remote Models)

Refrigerant line connections are made at the left end of merchandiser (facing front) beneath the refrigerated display area. The refrigerant line connection size is  $\frac{3}{8}$  in. The suction line is  $\frac{5}{8}$  in. Refrigerant lines should be sized as shown on the refrigeration legend that is furnished for the store or according to ASHRAE guidelines.



## WARNING

**Refrigeration lines are under pressure.  
Refrigerant must be recovered before  
attempting any connection or repair.**

For refrigerators with other than Koolgas defrost, the suction and liquid line should be clamped and/or taped together and insulated for a minimum of 30 feet from the refrigerator.

### KOOLGAS (Remote Models)

If Koolgas defrost is used, the liquid line will need to be increased two sizes larger inside the merchandiser area. This is necessary to ensure even liquid drainage from all evaporators during defrost.

Refrigerators with Koolgas defrost **SHOULD NOT** have their liquid lines and suction lines in contact with each other but are to be separately insulated for a minimum of 30 ft from the refrigerator. Additional information for the balance of the refrigerant lines is recommended and required wherever condensation and dripping would be objectionable.

**Oil Traps**

P-traps (oil traps) must be installed at the base of all suction line vertical risers.

**Pressure Drop**

Keep refrigerant line runs as short as possible to avoid large pressure drops. Use a minimum number of elbows. Where elbows are required, USE LONG RADIUS ELBOWS ONLY.

**COMPRESSOR****(Self Contained)**

The HGL compressor is mounted on vibration springs. The compressor is banded down during shipment. **This band MUST be cut and removed to allow the compressor to float freely once placed into operation.** Failure to cut compressor shipment band may result in excessive noise or system damage.

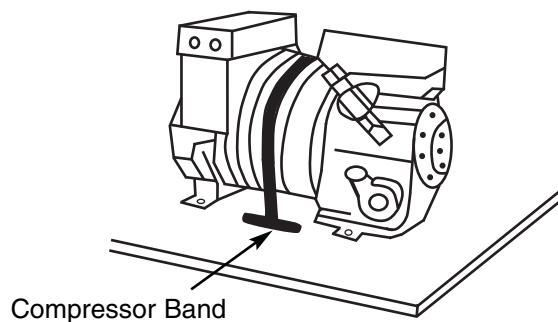
**CONDENSATE PAN**

An electrically heated (300W, 208-230V) condensate pan evaporates defrost water. The heated condensate pan slides onto the slide plate on the cabinet bottom on both the TS and BS merchandisers.

The pan is removable for cleaning. A vinyl drain tube is provided for connection to the heated condensate pan. The drain must be trapped to guard against drain line freezing and as a good sanitation practice.

**WARNING**

**Product will be degraded and may spoil if allowed to sit in a non-refrigerated area.**

**2-4 ELECTRICAL / REFRIGERATION**

**NOTES:**

## START UP / OPERATION



**...ATTENTION  
INSTALLER**

**It is the contractor's responsibility to  
install merchandiser(s) in accordance with  
all local building and health codes.**

### Safe-NET III™ TEMPERATURE AND DEFROST CONTROLLER

#### SAFE-NET III™ USER INSTRUCTIONS

Your refrigerated case uses a Hussmann Safe-NET™ III temperature and defrost controller to precisely maintain the temperature and prevent frost buildup on the cooling coil. LEDs indicate when the compressor or refrigeration is on, when the case is in a defrost cycle, if the temperature is outside the desired range, or if there is a sensor failure.

An adjustment knob allows the temperature to be set within the configured range and can power off the controller and compressor. Your controller has been custom-configured to provide the best temperature and defrost control for your chilled or frozen food.

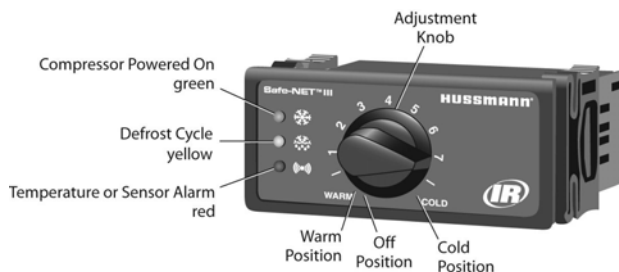

The front of the controller has an adjustment knob and status LEDs. The back of the controller has connections for sensors and switched equipment.

The Safe-NET III controller includes the following features and connections.

- Adjustment knob:  
Adjusts the temperature setpoint.  
Turn adjustment knob to OFF to turn off refrigeration system. Unplug merchandiser from power before servicing the unit.

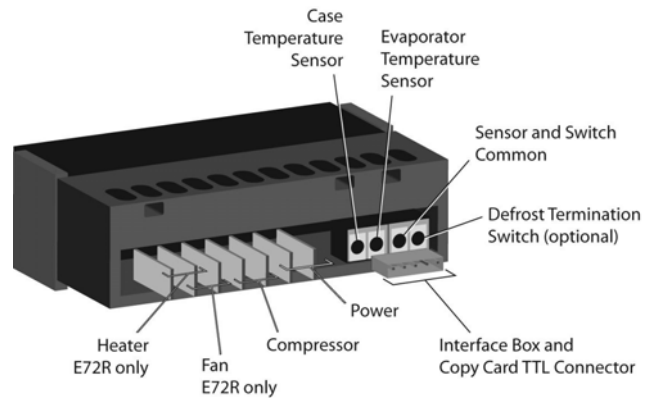

- Controller LEDs:
  - ❄️ Compressor Powered On LED (green):  
Lights while the compressor is running or the refrigeration valve is open.
  - ❄️ Defrost Cycle LED (yellow):  
Lights while the refrigeration coil is defrosting.
  - 🔊 Temperature or Sensor Alarm (red):  
Lights if the temperature is too warm or too cold. Flashes if a sensor fails.

- Rear connections:
  - Case temperature sensor:
    - Typically senses the temperature of the air in the case.  
Used by the controller to determine when to power on or power off the compressor or refrigeration.
  - Evaporator temperature sensor:
    - Senses the temperature of the refrigeration coil.  
Terminates a defrost cycle when refrigeration coil ice melts.
  - Compressor or refrigeration relay:
    - Switches on the compressor or refrigeration valve for cooling.



## WARNING

**The optional evaporator fan remains ON when the adjustment knob is in the Off position.**

## DISPLAY

The display includes three red LEDs and two digits for temperature, defrost status, and error codes.

The three display LEDs are red, and their behavior matches the LEDs on the controller.



## START-UP

Before applying power to the merchandiser, remove the front grille.

Locate the compressor (for self contained models), CUT THE BAND HOLDING THE COMPRESSOR IN PLACE. This band is only needed for shipment, and must be cut prior to operation.

Check thermostat knob is at the appropriate position. See temperature adjustment on Page 3-6.

Check the check the merchandiser's cabinet thoroughly for loose nuts and bolts. Check all electrical connections. Inspect the refrigerant lines for any visible damage or chafing.

Replace the front grille.

The following list of housekeeping practices will assure trouble-free operation:

- Check operation of condenser fan motors.  
Fan blades must turn freely.
- Check drain pan and heater to prevent accidental overflow.
- Make sure doors are closing properly, and that gaskets are sealed.
- Make sure all evaporator fan motors are running. These can be seen through grille inside of cabinet.

1. Plug in the merchandiser.



2. Wait for the self check to complete. During the self check, each LED flashes for one second, then all LEDs turn on for two seconds. If the LEDs do not flash, make sure the adjustment knob is not in the Off position.

- After the self check, all LEDs turn off until the compressor starts. **There may be a delay before the compressor starts.** If the red Temperature or Sensor Alarm LED stays on after the self check.
- The green Compressor Powered On LED turns on when the compressor starts.

**NOTE: Do NOT load product until AFTER merchandiser operates for 24 hours and reaches desired operating temperature.**



SEQUENCE OF OPERATION  
HGL BS/TS

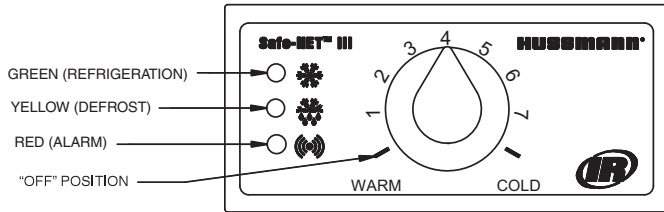
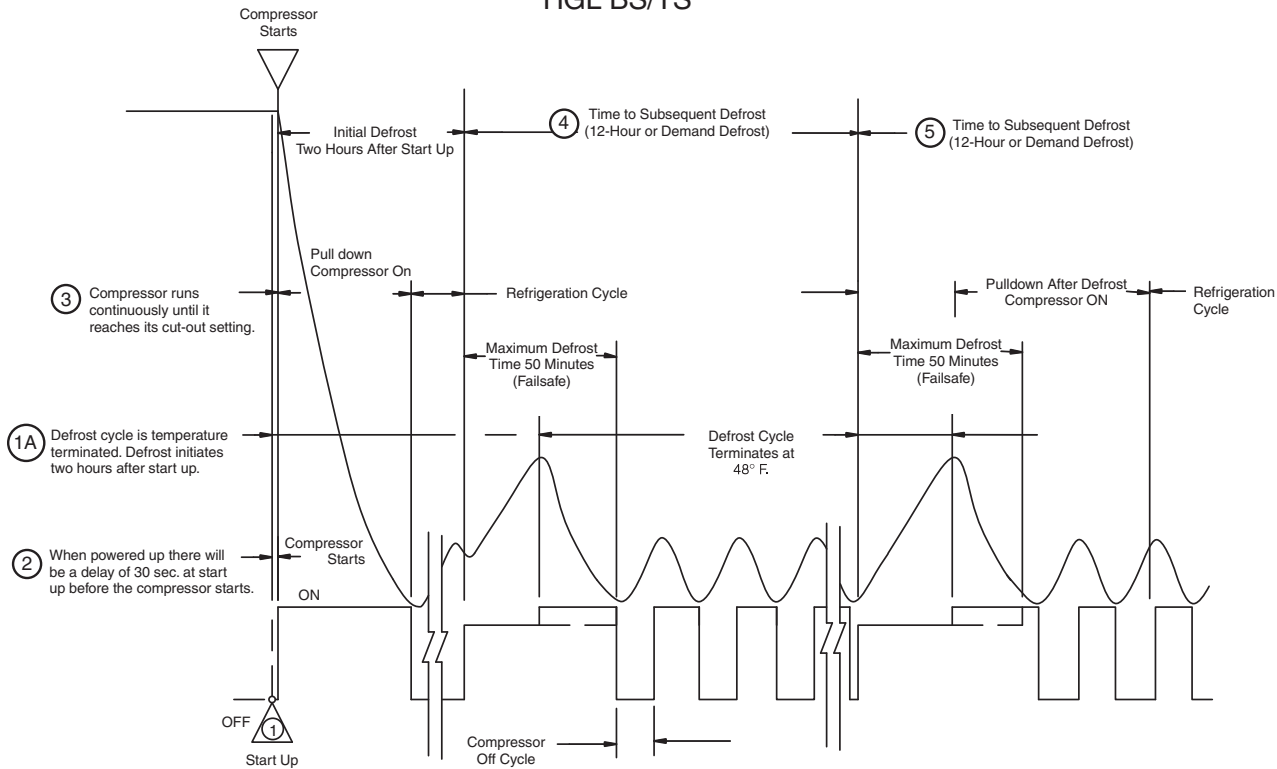

Safe-Net III Controller

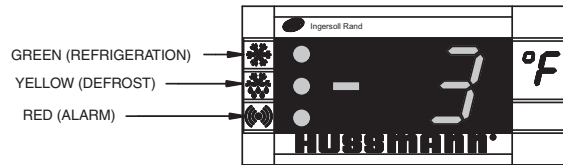

DISPLAY

1. Apply power to the merchandiser. Wait for the self check to complete. During the self check, each LED flashes for one second and then all LEDs turn on for two seconds. If the LEDs do not flash, make sure the adjustment knob is not in the "OFF" position.
- 1A. The merchandiser temperature displays at startup. The initial defrost starts two hours later. The display will show the temperature at the start of defrost. This reading will remain displayed during defrost and until it times out, even though the refrigeration mode has been initiated. (The green LED will be lit.)
2. The compressor will start after a delay; 30 seconds after the power is applied.
3. The compressor will continue to run until it reaches its cut-out temperature (Pulldown).
4. The refrigeration cycle will continue for the next subsequent scheduled 12-hours or demand defrost.
5. The above process will repeat (steps 3 and 4) until the power is interrupted.
6. If power stops, the process will start over at step 1, and the time to subsequent defrost will reset.

### ALARMS AND CODES

#### FLASHING TEMPERATURE OR SENSOR ALARM LED, E1 OR E2

If the Temperature or Sensor Alarm LED (red) on the controller and display is flashing, a temperature sensor has failed. The display shows E1 if the case sensor has failed or E2 if the evaporator sensor has failed.



If the merchandiser sensor fails, refrigeration will run continuously. Turn off, or repeat a duty cycle of a few minutes on and a few minutes off.

### DEFROST TERMINATION SWITCH

Merchandisers may use a defrost termination switch, instead of an evaporator sensor to terminate a defrost cycle. The defrost termination switch is temperature activated and senses the completion of defrost.

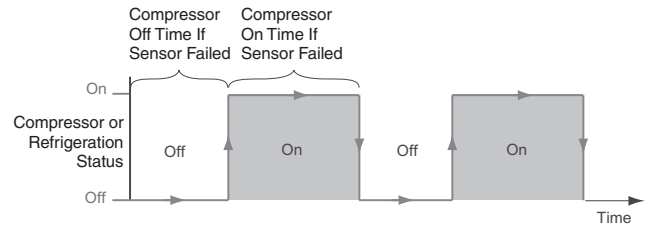

### MANUAL DEFROST

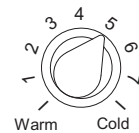

1. Note location of knob setting

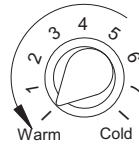

2. Rotate knob fully counterclockwise until it stops (full warm - "OFF" position)

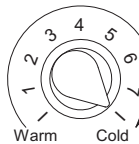

3. After 10 seconds, but before 20 seconds, rotate knob fully clockwise until it stops (full cold position)

Note:  
***This procedure initiates a manual or forced defrost.***

**IMPORTANT:** Return the control knob to its original setting (Step 1) once the manual defrost has been initiated.

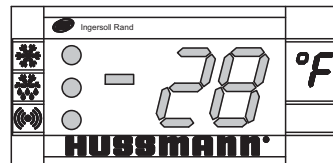
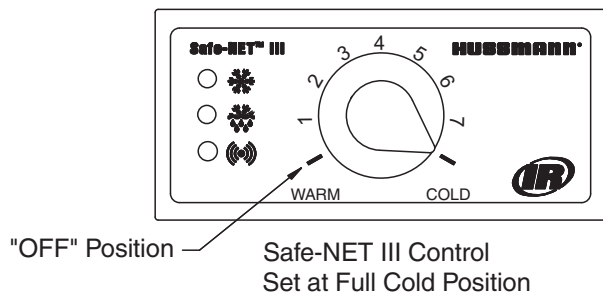

Display - at Full Cold  
Model HGL

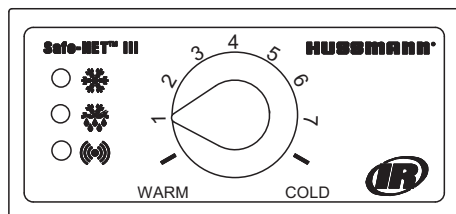

Safe-NET III Control  
# 1 Position

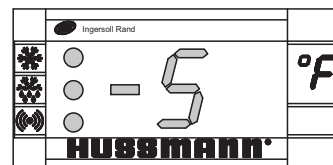

Display - at #1 Position  
Model HGL

## TEMPERATURE ADJUSTMENT

1. Rotate the adjustment knob counter clockwise for a warmer setpoint or clockwise for a colder setpoint.
2. While adjusting the temperature, the display shows the setpoint (cut out value). A few seconds after the temperature is set, the controller reverts to the sensed temperature in the merchandiser.
3. To verify merchandiser settings, perform the operations below. Output readings should be within one degree of the temperatures shown above.

### Typical Sensor to Control Configuration

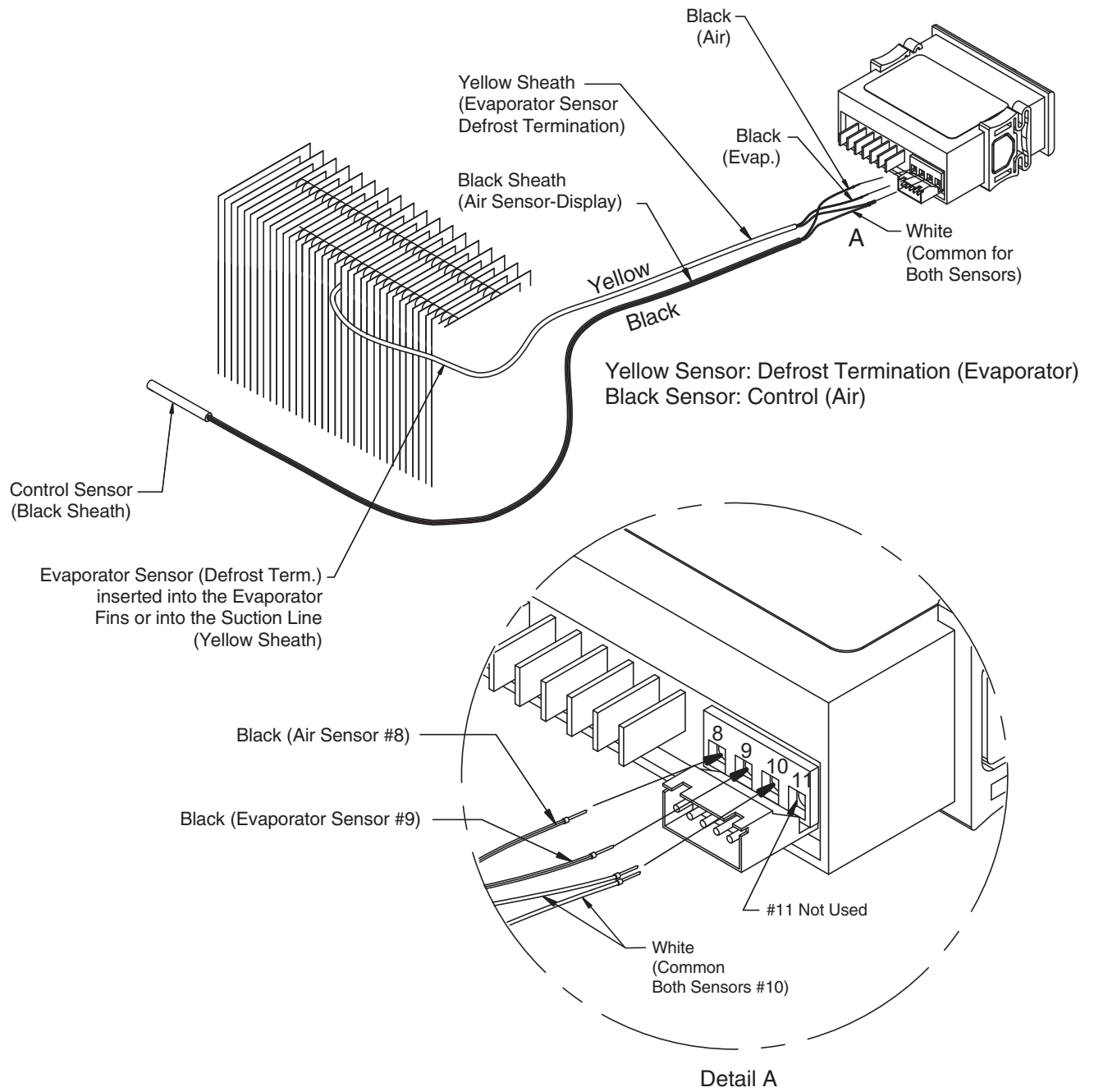

## CONTROLS and ADJUSTMENTS

Refrigeration Controls			Defrost Controls			
Model	Product Application	Discharge Air Temperature	Defrost Frequency (per day)	Type of Defrost	Temp. Termination	Failsafe Time (Minutes)
<b>HGL</b> (Remote and Self Contained)	Low Temp. (Frozen Food)	-5° to -15° F	3	Electric	48° F	50

1. The Safe-NET III Controller controls refrigeration temperature. This is factory installed in the control panel. Adjust this control knob to maintain the discharge air temperature shown. Measure discharge air temperatures at the center of the discharge louver.

Defrosts are time initiated and temperature terminated for self contained and remote, including Koolgas models. The defrost setting is factory set as shown above.

To ensure a thorough defrost, defrost must be terminated by the temperature termination setting — not by time.

## START UP

Follow the Safe-NET III start up procedures as detailed in Section 3 of this manual.

Each self contained merchandiser has its own evaporator coil and a pre-set thermostatic expansion valve (TEV). The TEV has been factory set at design conditions to provide the recommended performance.

## CRANKCASE PRESSURE REGULATOR

The HGL-1 and HGL-2 merchandisers employ a crankcase pressure regulator in the suction line. The CPR is set for 10 psi. The purpose of the valve is to maintain a low suction pressure on startup so that the compressor will start properly. On start-up, the valve will hold the suction pressure at the desired setting until the suction pressure drops below the setting, then the valve will open. If it becomes necessary to check or reset the setting, the merchandiser must be warm such as after a defrost cycle or from an initial warm case condition.

Put a suction compound gauge on the compressor suction valve. Start the compressor. If the pressure needs to be reduced, turn the adjustment screw clockwise or counterclockwise to raise the pressure.

**DO NOT SET THE VALVE BASED ON THE SERIAL PLATE AMPERAGE RATING AS THE PRESSURE SETTING WILL BE TOO HIGH, AND THE COMPRESSOR WILL NOT START PROPERLY.**

## RECEIVER

The receiver should not be confused for a filter-drier or muffler. The receiver is in the liquid line after the condenser and just ahead of the filter drier. The manufacturer may label the receiver as a muffler or a drier, but it is in fact, an empty shell.



## COMPRESSOR

HGL self contained merchandiser has a compressor that is banded down for shipment. **This band MUST be cut and removed to allow the compressor to float freely once placed into operation.**

**NOTE:** Failure to cut compressor shipment band may result in excessive noise or system damage, which is not covered by warranty.

### TEV Adjustment

Expansion valves may be adjusted to fully feed the evaporator. Before attempting to adjust valves, make sure the evaporator is clear or only lightly covered with frost, and the merchandiser is within 10°F of its expected operating temperature.

Adjust the valve as Follows:

- a. Attach a probe to the suction line near the expansion valve bulb.
- b. Obtain a pressure reading from the factory installed Schraeder valve. Convert the pressure reading to a saturated temperature for the refrigerant.

Temperature (b) minus Temperature (a) is the superheat. The valve should be adjusted so that the greatest difference between the two temperatures is 3°F to 5° F.

Make adjustments of no more than 1/2 turn of the valve stem at a time and wait for at least 15 minutes before rechecking the probe temperature and making further adjustments.

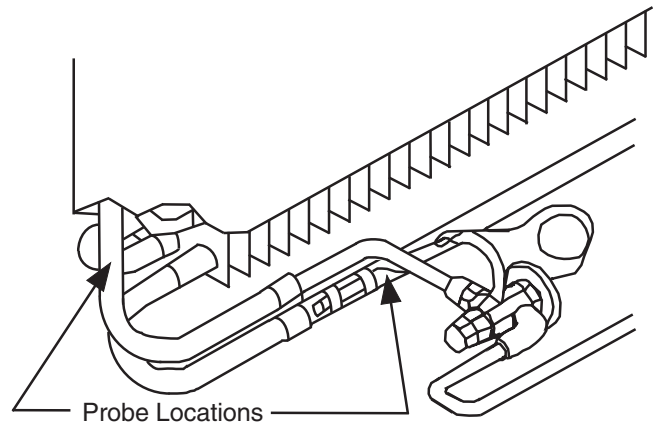

**LOAD LIMITS**

Each merchandiser has a load limit decal. Shelf life of perishables will be short if load limit is violated.



**AT NO TIME SHOULD MERCHANDISERS BE STOCKED BEYOND THE LOAD LIMITS INDICATED.**

**DO NOT BLOCK AIR LOUVERS.**

**STOCKING**

Product should NOT be placed inside the merchandisers until merchandisers are at proper operating temperature.

**Allow merchandiser 24 hours to operate before loading product.**

Proper rotation of product during stocking is necessary to prevent product loss. Always bring the oldest product to the front and set the newest to the rear.

AIR DISCHARGE AND RETURN FLUES MUST REMAIN OPEN AND FREE OF OBSTRUCTION AT ALL TIMES to provide proper refrigeration and air curtain performance. Do not allow product, packages, signs, etc. to block these grilles. Do not use non-approved shelving, baskets, display racks, or any accessory that could hamper air curtain performance.

Do not allow product to be placed outside of the designated load limits in the illustration.

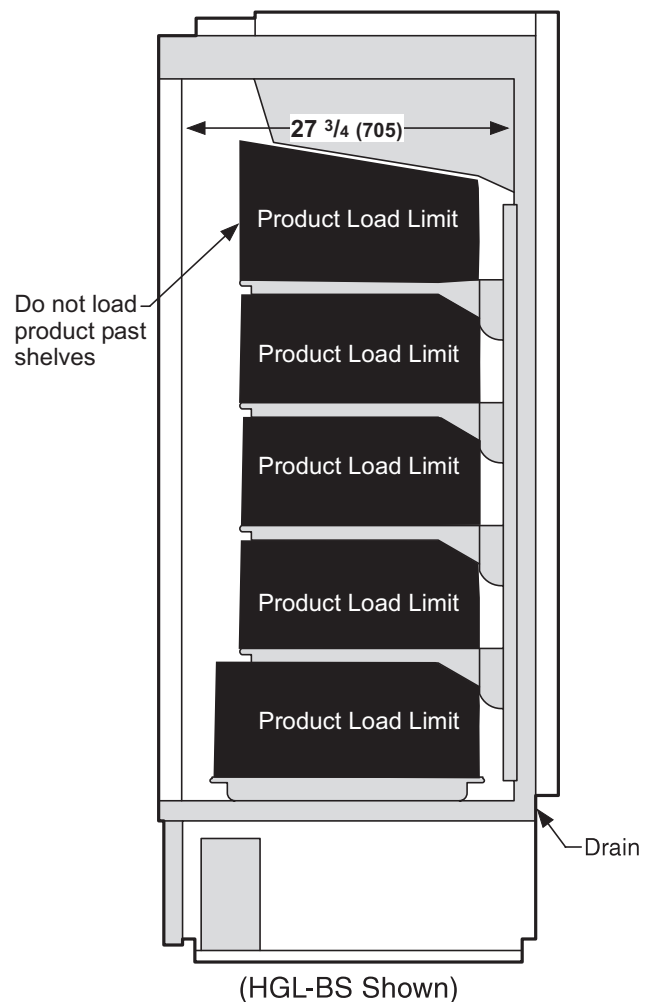

## THERMOMETER

The thermometer is located by looking through the right hand door onto the right hand end of the fan grille. The thermometer will warm up rapidly when the merchandiser door is held open, or when the merchandiser is being restocked. After the door is closed it will take some time for the thermometer to decrease to optimal temperature. The thermometer and temperature control senses discharge air temperature, which is 5° to 10° F colder than the merchandiser temperature.

## LIGHTING

Electronically powered T-8 lamps, located inside each doorway, provide interior lighting. The tubes are enclosed in a patented lens system to maintain proper heat around the bulb for maximum light intensity. The tubes also protect the product in case of breakage.

Each HGL model has an ON/OFF switch so lights may be turned off to conserve energy during hours when the store is closed. The switch is located inside the cabinet above the left-hand door. This switch only controls the lights. 208-230 V power must be shut off at the main disconnect, located within the store prior to starting any service or maintenance work.

Light ballasts are located in mullions of the door frames.

## LED LIGHTS

LED lights are optional features. For details showing how the LED fixtures are mounted, see the supplemental document shipped with the merchandiser.

## DOOR SWITCHES

The switches at the top of the doorways operate the evaporator fan motors. These switches stop the fan motors when the doors are open.

## DOOR DEFROST HEATER THERMOSTAT

This cabinet is equipped with both frame and door heaters. These are thermostatically controlled, and will not come on until the cabinet is at operating temperature.

## ALARM THERMOSTAT (heater display)

The alarm (heater display) thermostat is located on the top of the inner liner in the upper right hand corner behind the evaporator. The thermostat will not turn the heaters on until it senses 0° F, and in turn will turn the heaters off when it senses +18° F. This is because the unwanted heat will not be added to the merchandiser during defrost or if the case refrigeration system fails.

## MAINTENANCE

### CARE AND CLEANING

Long life and satisfactory performance of any equipment is dependent upon the care it receives. To ensure long life, proper sanitation and minimum maintenance costs, these merchandisers should be thoroughly cleaned, all debris removed and the interiors washed down, weekly.

#### Exterior Surfaces

The exterior surfaces must be cleaned with a mild detergent and warm water to protect and maintain their attractive finish. **NEVER USE ABRASIVE CLEANSERS OR SCOURING PADS.**

#### Interior Surfaces

The interior surfaces may be cleaned with most domestic detergents, ammonia based cleaners and sanitizing solutions with no harm to the surface. Self contained models empty into a limited capacity condensate pan, which will overflow if excess water is used in cleaning.

### *Do NOT Use:*

- Abrasive cleansers and scouring pads, as these will mar the finish.
- Coarse paper towels on coated glass.
- Ammonia-based cleaners on acrylic parts.
- Solvent, oil or acidic based cleaners on any interior surfaces.
- Do not use high pressure water hoses.



### WARNING

Product will be degraded and may spoil if allowed to sit in a non-refrigerated area.

### *Do:*

- Remove the product and all loose debris to avoid clogging the waste outlet.
- Store product in a refrigerated area such as a cooler. Remove only as much product as can be taken to the cooler in a timely manner.
- Disconnect electrical power before cleaning.**
- Thoroughly clean all surfaces with soap and hot water. **DO NOT USE STEAM OR HIGH WATER PRESSURE HOSES TO WASH THE INTERIOR. THESE WILL DESTROY THE MERCHANDISERS' SEALING CAUSING LEAKS AND POOR PERFORMANCE.**
- Take care to minimize direct contact between fan motors and cleaning or rinse water.



### WARNING

**Do NOT allow cleaning agent or cloth to contact food product.**

- Do NOT flood merchandiser with water. **NEVER INTRODUCE WATER FASTER THAN THE WASTE OUTLET CAN REMOVE IT.**

**SELF CONTAINED MODELS EMPTY INTO AN CONDENSATE PAN THAT WILL OVERFLOW IF TOO MUCH WATER IS INTRODUCED DURING CLEANING.**

- Allow merchandisers to dry before resuming operation.
- After cleaning is completed, turn on power to the merchandiser.

## CLEANING STAINLESS STEEL SURFACES

Use non-abrasive cleaning materials, and always polish with grain of the steel. Use warm water or add a mild detergent to the water and apply with a cloth. Always wipe rails dry after wetting.

Use alkaline chlorinated or non-chlorine containing cleaners such as window cleaners and mild detergents. Do not use cleaners containing salts as this may cause pitting and rusting of the stainless steel finish. Do not use bleach.



## WARNING

— LOCK OUT / TAG OUT —

*To avoid serious injury or death from electrical shock, always disconnect the electrical power at the main disconnect when servicing or replacing any electrical component. This includes, but is not limited to, such items as doors, lights, fans, heaters, and thermostats.*



## WARNING

**Do NOT use HOT water on Cold glass Surfaces. This can cause the glass to shatter and could result in personal injury. Allow glass fronts, to warm before applying hot water.**

## CLEANING COILS

Condenser coils should be cleaned at least once per month. Additional cleaning may be needed depending on the operational environment. A dirty condenser blocks normal airflow through the coils.



Airflow blockage increases energy consumption and reduces the merchandiser's ability to maintain operating temperature.

To clean the coils, use a vacuum cleaner with a wand attachment and a soft (non-metallic) brush to remove dirt and debris. Do not bend coil fins. Always wear gloves and protective eye wear when cleaning near sharp coil fins and dust particles.

**Unplug merchandiser before servicing. Always wear gloves and protective eye wear when cleaning coils.**



**CLEANING CONDENSATE PAN**  
(SELF CONTAINED ONLY)

The condensate water outlet for self contained models empties into a limited capacity condensate pan.

Debris or dirt accumulation inside the condensate pan or on the heater coil will reduce the pan's evaporation capacity and cause premature heater failure. The condensate pan waste will overflow and spill onto the floor if the heater is not properly operating.

Always wear protective eye wear and gloves when servicing.

Remove accumulated debris from the condensate pan. Wipe down heater coil with a cloth and warm water. Be sure to remove any dirt, debris or liquids from the heater coil.

Water introduced during cleaning will cause the condensate pan to overflow.

**Unplug merchandiser before servicing. Always wear gloves and protective eye wear when cleaning condensate pan.**



## CAUTION

**Condensate Pan is Hot!**  
and poses risk of bodily injury – Always Wear gloves and protective eye wear when servicing. Turn off condensate pan heater, and allow pan to cool.





## CAUTION

**DO NOT FLOOD!**  
**Use only enough water necessary to clean surface. Water must not drip down the case!**

**Never use ammonia based cleansers, abrasive cleansers, or scouring pads.**



PRECAUTION  
CLEANING PRECAUTIONS

When Cleaning:

- Do not use high pressure water hoses
- Do not introduce water faster than waste outlet can drain
- NEVER INTRODUCE WATER ON SELF CONTAINED UNIT WITH AN EVAPORATION PAN
- NEVER USE A CLEANING OR SANITIZING SOLUTION THAT HAS OIL BASE (these will dissolve the butyl sealants) or an AMMONIA BASE (this will corrode the copper components of the merchandiser)
- TO PRESERVE THE ATTRACTIVE FINISH:
- Use a water and a mild detergent for the exterior only
- Do NOT use a chlorinated cleaner on any surface
- Do NOT use abrasives or steel wool scouring pads (these will mar the finish)

**4-4 MAINTENANCE**

**NOTES:**

## SERVICE

### REPLACING FAN MOTORS AND BLADES

Should it ever be necessary to service or replace the fan motors or blades be certain that the fan blades are reinstalled correctly.

**THE BLADES MUST BE INSTALLED WITH RAISED EMBOSING (PART NUMBER ON PLASTIC BLADES) POSITIONED AS INDICATED ON THE PARTS LIST.**

#### For access to these fans:

1. Remove product and place in a refrigerated area. Turn off power to the merchandiser.
2. Remove two thumb screws that secure the return air grille / coil cover.
3. **Remove return air grille.**
4. Remove fan assembly.
5. Replace fan motor and blade.
6. Reconnect fan to wiring harness.
7. Replace return air grille, and fasten air grille to coil cover.
8. Turn on power.
9. Verify that motor is working and blade is turning in the correct direction.



### WARNING

**Product will be degraded and may spoil if allowed to sit in a non-refrigerated area.**



### WARNING

#### — LOCK OUT / TAG OUT —

***To avoid serious injury or death from electrical shock, always disconnect the electrical power at the main disconnect when servicing or replacing any electrical component. This includes, but is not limited to, such items as doors, lights, fans, heaters, and thermostats.***

### REPLACING THERMOMETER

The thermometer may be replaced by removing the two screws holding it to the evaporator fan grille. Lower the evaporator coil cover by removing the brass screws located at the two front corners of the cover. Remove the screws along the front edge of the cover holding it to the grille. Follow the sensing lead to the center rear of the evaporator coil. Loosen the clip holding it to the bracket, and slide the end of the lead out.

When installing the new thermometer be sure to run the lead of the new thermometer through the hole in the fan grille first. Finish assembly in reverse order. The same procedures should be followed when cleaning the end of the sensing lead.

### DEFROST HEATER REPLACEMENT

The defrost heaters are firmly embedded in the evaporator and held in place with spring clips. To remove the heater: first remove all spring clips and pull the defective heater out of the slots in the evaporator, starting at the wire supply lead.

The replacement heater should be firmly seated in the slots by using a small block of wood and a mallet. After the new heater is in place, replace all the spring retaining clips to assure heater retention. One lead of the defective heater may be used to pull the new leads through the cabinet to the respective terminals as marked on each lead.

**NOTE:** Care must be taken to ensure the drain stub is correctly inserted in the cabinet drain tube for proper drainage.

## TROUBLESHOOTING GUIDE

PROBLEM	PROBABLE CAUSE	SOLUTION
Compressor runs continuously product too warm	<ol style="list-style-type: none"> <li>1. Short of refrigerant</li> <li>2. Inefficient compressor</li> <li>3. Dirty condenser</li> </ol>	<ol style="list-style-type: none"> <li>1. Leak check, change drier, evacuate, and recharge</li> <li>2. Replace</li> <li>3. Clean</li> </ol>
High head pressure	<ol style="list-style-type: none"> <li>1. Cabinet location too warm</li> <li>2. Restricted condenser air flow</li> <li>3. Defective condenser fan motor</li> <li>4. Air or non-condensable gases in system</li> </ol>	<ol style="list-style-type: none"> <li>1. Relocate cabinet</li> <li>2. Clean condenser to remove air flow restriction</li> <li>3. Replace</li> <li>4. Leak check, change drier, evacuate and recharge</li> </ol>
Warm storage temperature	<ol style="list-style-type: none"> <li>1. Temperature control not set properly</li> <li>2. Short of refrigerant</li> <li>3. Cabinet location too warm</li> <li>4. Too much refrigerant</li> <li>5. Low voltage, compressor cycling on overload</li> <li>6. Condenser dirty</li> </ol>	<ol style="list-style-type: none"> <li>1. Reset control.</li> <li>2. Leak check, replace drier evacuate and recharge</li> <li>3. Relocate</li> <li>4. Change drier evacuate and recharge</li> <li>5. Check power</li> <li>6. Clean</li> </ol>
Compressor runs continuously product too cold	<ol style="list-style-type: none"> <li>1. Defective control</li> <li>2. Control feeler not in tube properly</li> <li>3. Short on refrigerant</li> </ol>	<ol style="list-style-type: none"> <li>1. Replace</li> <li>2. Assure proper length in tube</li> <li>3. Leak check change drier, evacuate and recharge</li> </ol>

<b>PROBLEM</b>	<b>PROBABLE CAUSE</b>	<b>SOLUTION</b>
Compressor runs continuously product too cold	<ol style="list-style-type: none"> <li>1. Defective control</li> <li>2. Control feeler not in tube properly</li> <li>3. Short on refrigerant</li> </ol>	<ol style="list-style-type: none"> <li>1. Replace</li> <li>2. Assure proper length in tube</li> <li>3. Leak check change drier, evacuate and recharge</li> </ol>
Compressor will not start no noise	<ol style="list-style-type: none"> <li>1. Blown fuse or breaker</li> <li>2. Defective or broken wiring</li> <li>3. Defective overload</li> <li>4. Defective temperature control</li> <li>5. Power disconnected</li> </ol>	<ol style="list-style-type: none"> <li>1. Replace fuse or reset breaker</li> <li>2. Repair or replace</li> <li>3. Replace</li> <li>4. Replace</li> <li>5. Check service cords or wiring connections</li> </ol>
Compressor will not start cuts out on overload	<ol style="list-style-type: none"> <li>1. Low voltage</li> <li>2. Defective compressor</li> <li>3. Defective relay</li> <li>4. Restriction or moisture</li> <li>5. Inadequate air over condenser</li> <li>6. Defective condenser fan motor</li> <li>7. CRO not set properly</li> </ol>	<ol style="list-style-type: none"> <li>1. Contact electrician</li> <li>2. Replace</li> <li>3. Replace</li> <li>4. Leak check, replace drier, evacuate and recharge</li> <li>5. Clean condenser</li> <li>6. Replace</li> <li>7. Reset to 10 psi.</li> </ol>

PROBLEM	PROBABLE CAUSE	SOLUTION
Icing condition in drain pan	<ol style="list-style-type: none"> <li>1. Low voltage</li> <li>2. Cabinet not level</li> <li>3. Defective drain tube heater</li> <li>4. Defective drain pan heater</li> </ol>	<ol style="list-style-type: none"> <li>1. Check voltage at compressor</li> <li>2. Check front to rear leveling, adjust legs accordingly</li> <li>3. Replace</li> <li>4. Replace</li> </ol>

**LIGHTING PROBLEM / SOLUTION**

PROBLEM	SOLUTION
Lights won't start	<ol style="list-style-type: none"> <li>1. Check light switch</li> <li>2. Check continuity to ballast</li> <li>3. Check to see if bulbs are inserted properly in sockets</li> <li>4. Check voltage</li> </ol>
Lights flicker	<ol style="list-style-type: none"> <li>1. Allow lamps to warm up</li> <li>2. Check sleeve for cracks</li> <li>3. Check sockets for moisture and proper contact</li> <li>4. Bulb replacement may be necessary</li> <li>5. Check voltage</li> <li>6. New bulbs tend to flicker until used</li> </ol>
Ballast hums	<ol style="list-style-type: none"> <li>1. Check voltage</li> <li>2. Replace ballast</li> </ol>

<b>Item Part #</b>	<b>Description</b>	<b>Item Part #</b>	<b>Description</b>
<b>HGL-1 HGL-2 HGL-3</b>		<b>REFRIGERATION</b>	
<b>PARTS (ALL MODELS)</b>		<b>HGL-1</b>	
<b>5W Standard</b>	Fan Assembly	CU.4200232	Compressor
MO.4410291	Fan Motor, 5 Watt – 208V/230V	CO.25S040	Condenser
FB.4780606	Fan Blade	MO.4410827	Condenser Fan Motor
CT.4483088	Safe Net III Controller	FB.4780794	Condenser Fan Blade
CC.4482991	Defrost Sensor (Yellow)	EV.4671169	Evaporator
CC.4482992	Air Sensor (Black)	VR.175444	TXV
CC.4482540	Safe Net III Display (°F)	FI.4612642	Filter Drier
EP.4483064	Safe Net III Harness		
		<b>HGL-2</b>	
EP.4441283	HGL-1 / HGM-2 Power Cord 15 Amp, 208-230V	CU.8420119	Compressor
EP.4441278	HGL-3 Power Cord 20 Amp, 208-230V	CO.25S040	Condenser
SW.4440542	Power Switch - all models	MO.4410827	Condenser Fan Motor
CT.4481967	Alarm Tstat	FB.4780794	Condenser Fan Blade
RL.4441382	Compressor Relay	EV.4671160	Evaporator
RL.4441382	Defrost Relay	VR.17S444	TXV
VR.4613171	CPR Valve	FI.4612642	Filter Drier
DO.29S7931	Door Assembly (Silver)		

**A-2            APPENDIX A — TECHNICAL DATA**

<b>Item Part #</b>	<b>Description</b>	<b>Item Part #</b>	<b>Description</b>
<b>REFRIGERATION (CONTINUED)</b>		<b>HGL-2</b>	
<b>HGL-3</b>		HE.4850852	Defrost Heater
CU.8420123	Compressor	HE.4851201	Drain Heater
CO.4670393	Condenser	HE.4850861	Drain Pan Heater
MO.4410827	Condenser Fan Motor	HE.4850846	Condensate Pan Heater
FB.4780788	Condenser Fan Blade	DP.4916279	Condensate Pan
EV.4671074	Evaporator		
VR.17S115	TXV	<b>HGL-3</b>	
FI.4612642	Filter Drier	HE.4850744	Defrost Heater
		HE.4850744	Drain Heater
<b>HEATERS</b>		HE.4850324	Drain Pan Heater
<b>HGL-1</b>		HE.4850846	Condensate Pan Heater
HE.4850905	Defrost Heater	DP.4916279	Condensate Pan
HE.4851200	Drain Heater		
HE.4850896	Drain Pan Heater		
DP.4996638	Condensate Pan Heater		
DP.4916279	Condensate Pan		

**HGL-1BS — Plan View**

Dimensions shown as inches and (mm).

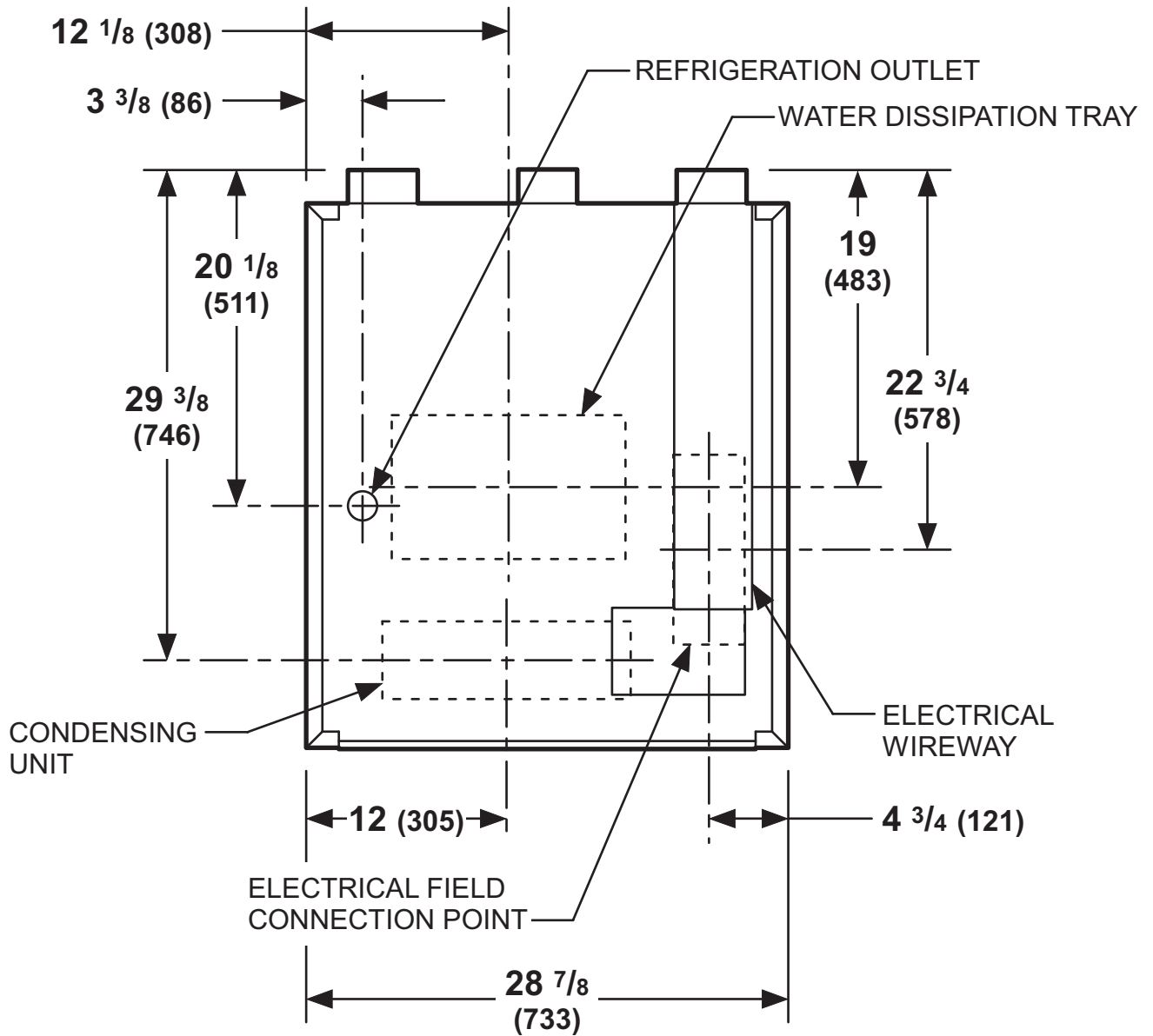

**HGL-2BS & HGL-3BS — Plan View**

Dimensions shown as inches and (mm).

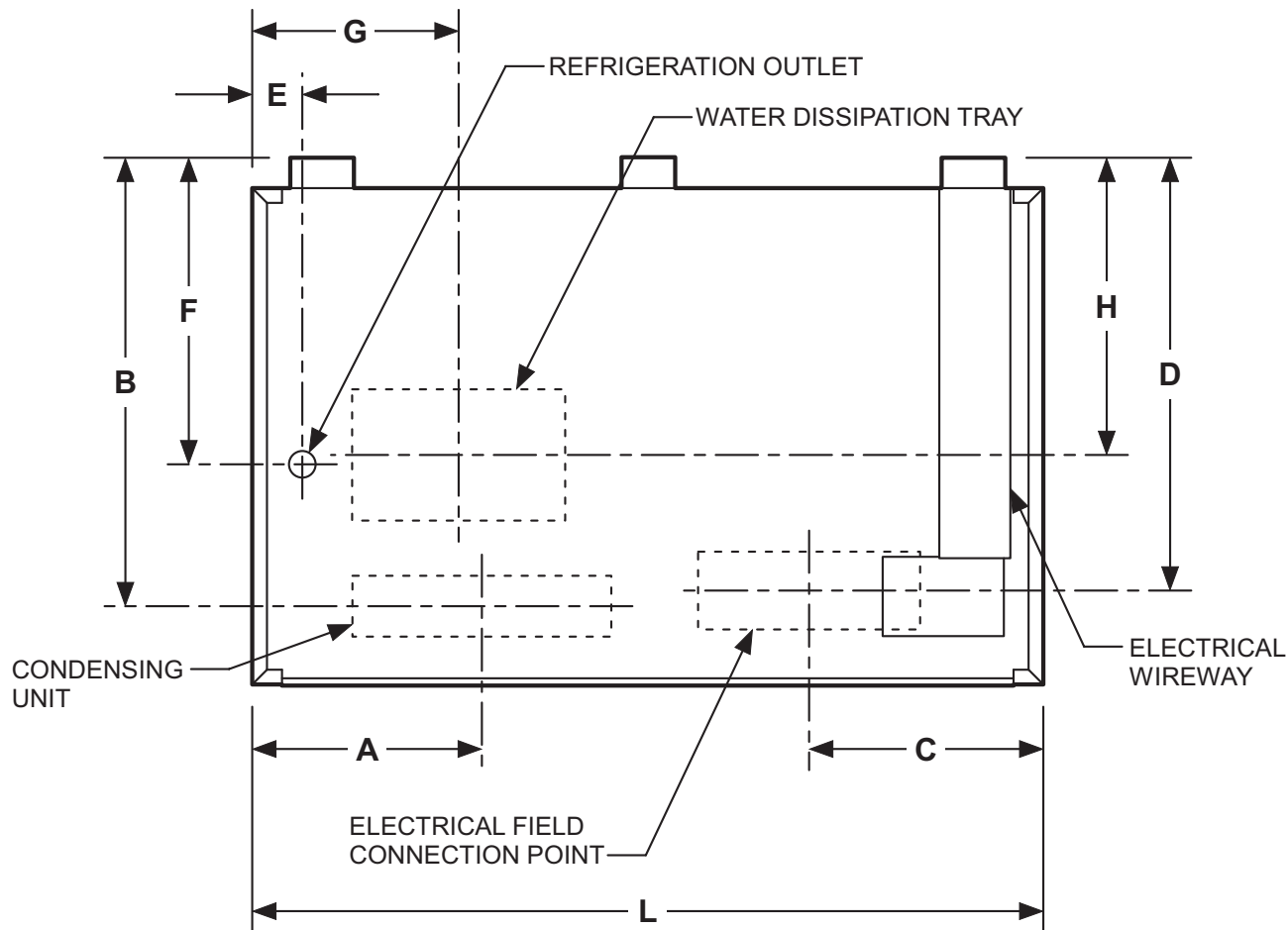

Dimensions shown as inches and (mm).

Model	HGL-2BS	HGL-3BS
A	13 1/2 (343)	16 1/8 (410)
B	29 1/2 (749)	27 (686)
C	15 3/8 (391)	15 3/8 (391)
D	27 3/8 (695)	27 1/2 (699)
E	3 1/4 (83)	3 3/8 (86)
F	20 1/8 (511)	20 1/8 (511)
G	13 5/8 (346)	16 1/2 (419)
H	19 1/8 (486)	15 1/8 (384)
Length (L)	52 (1321)	75 3/8 (1915)

**HGL-1TS — Plan View**

Dimensions shown as inches and (mm).

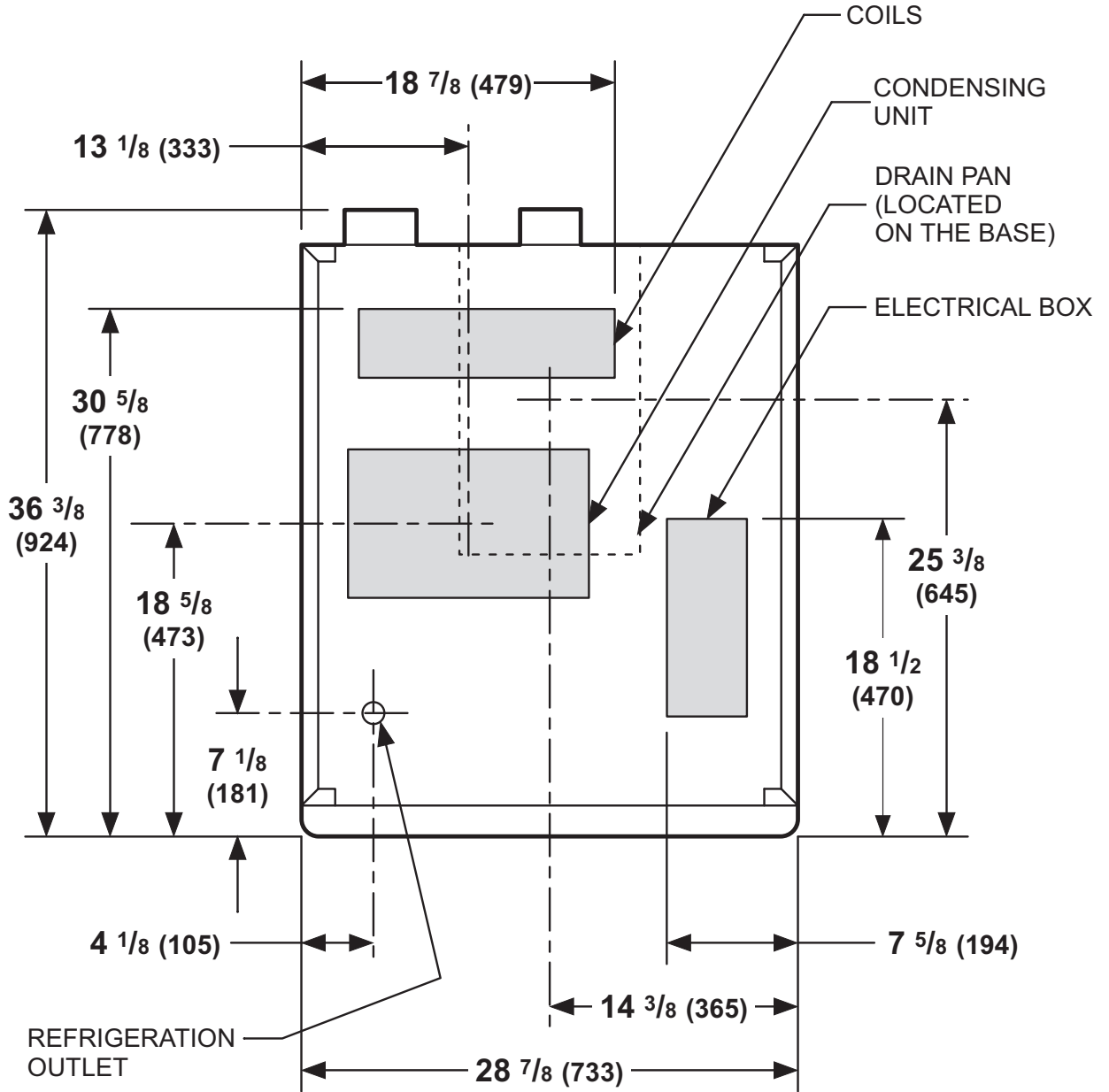

**HGM-2TS — Plan View**

Dimensions shown as inches and (mm).

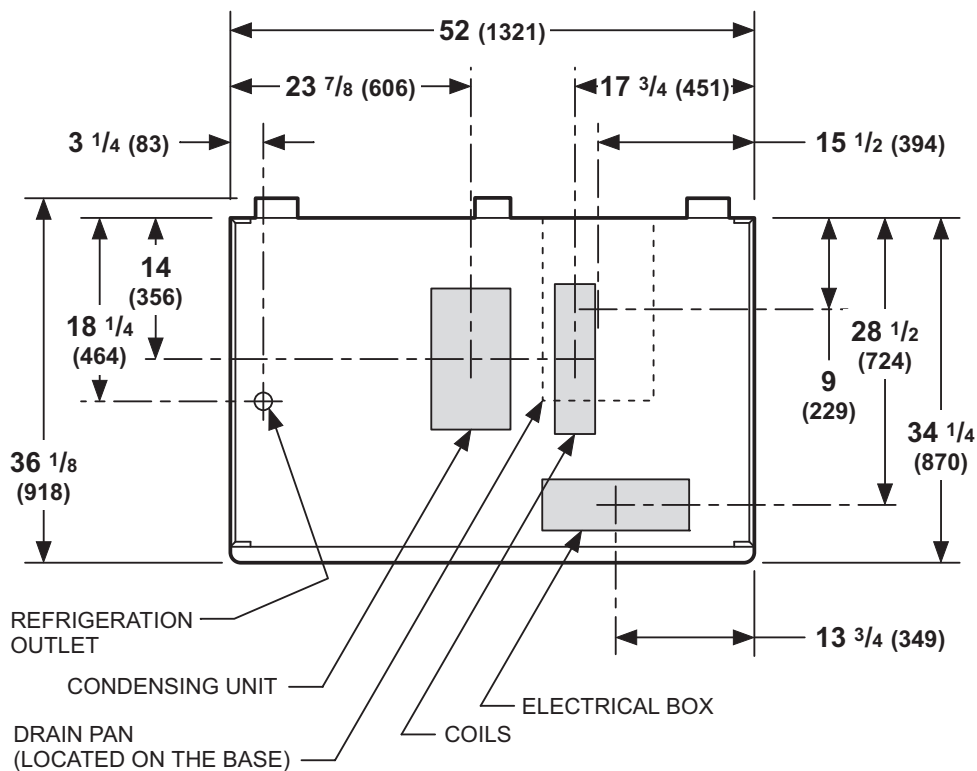

**HGM-3TS — Plan View**

Dimensions shown as inches and (mm).

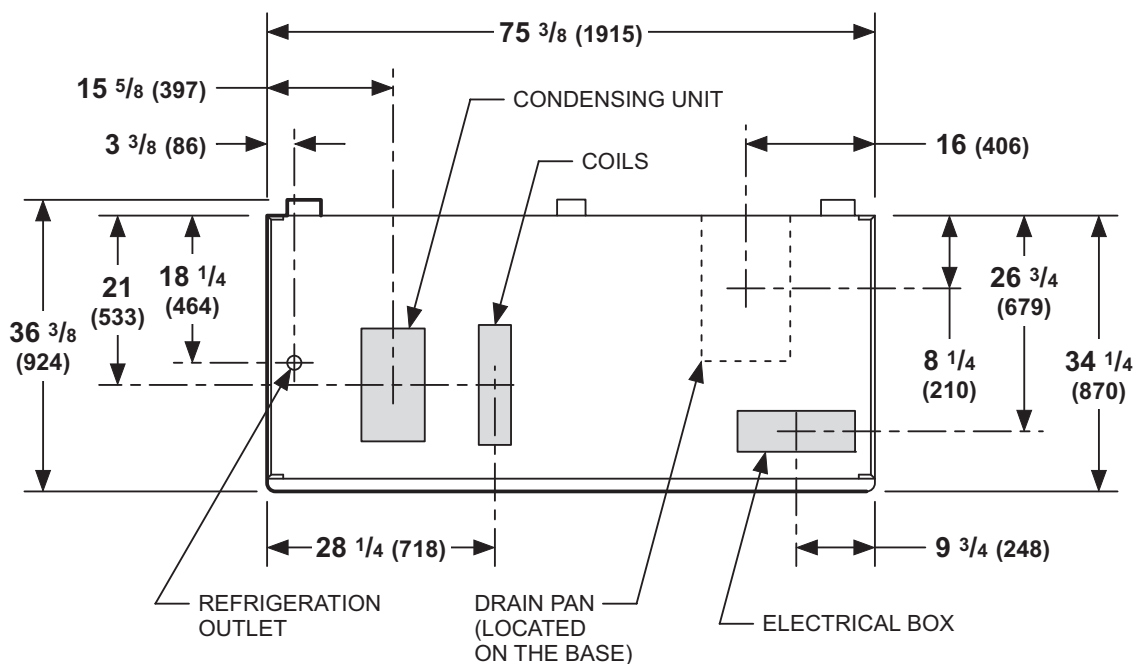

**HGL — Dimensions**

Model	Exterior Dimensions (inches)			Interior Volume [liters] (cubic feet)	Nominal HP	Refrigerant Type	Volts	Run Amps
	L	D	H					
HGL-1BS	28 <sup>7</sup> / <sub>8</sub>	34 <sup>5</sup> / <sub>8</sub>	80 <sup>9</sup> / <sub>16</sub>	685 (24.19)	<sup>3</sup> / <sub>4</sub>	R-404A	208/230	8.4
HGL-1B	28 <sup>7</sup> / <sub>8</sub>	34 <sup>5</sup> / <sub>8</sub>	80 <sup>9</sup> / <sub>16</sub>	685 (24.19)	—	R-404A	208/230	7.9
HGL-2BS	52	34 <sup>5</sup> / <sub>8</sub>	80 <sup>9</sup> / <sub>16</sub>	1327 (46.86)	1	R-404A	208/230	9.5
HGL-2B	52	34 <sup>5</sup> / <sub>8</sub>	80 <sup>9</sup> / <sub>16</sub>	1327 (46.86)	—	R-404A	208/230	8.9
HGL-3BS	75 <sup>3</sup> / <sub>8</sub>	34 <sup>5</sup> / <sub>8</sub>	80 <sup>9</sup> / <sub>16</sub>	1999 (70.60)	1 <sup>1</sup> / <sub>2</sub>	R-404A	208/230	12.5
HGL-3B	75 <sup>3</sup> / <sub>8</sub>	34 <sup>5</sup> / <sub>8</sub>	80 <sup>9</sup> / <sub>16</sub>	1999 (70.60)	—	R-404A	208/230	10.2

\*Field hard wired

Model	Exterior Dimensions (inches)			Interior Volume [liters] (cubic feet)	Nominal HP	Refrigerant Type	Volts	Run Amps
	L	D	H					
HGL-1TS	28 <sup>7</sup> / <sub>8</sub>	36 <sup>1</sup> / <sub>8</sub>	84 <sup>1</sup> / <sub>4</sub>	685 (24.19)	<sup>3</sup> / <sub>4</sub>	R-404A	208/230	8.4
HGL-1T	28 <sup>7</sup> / <sub>8</sub>	36 <sup>1</sup> / <sub>8</sub>	84 <sup>1</sup> / <sub>4</sub>	685 (24.19)	—	R-404A	208/230	7.9
HGL-2TS	52	36 <sup>1</sup> / <sub>8</sub>	84 <sup>1</sup> / <sub>4</sub>	1327 (46.86)	1	R-404A	208/230	9.5
HGL-2T	52	36 <sup>1</sup> / <sub>8</sub>	84 <sup>1</sup> / <sub>4</sub>	1327 (46.86)	—	R-404A	208/230	8.9
HGL-3TS	75 <sup>3</sup> / <sub>8</sub>	36 <sup>1</sup> / <sub>8</sub>	84 <sup>1</sup> / <sub>4</sub>	1999 (70.60)	1 <sup>1</sup> / <sub>2</sub>	R-404A	208/230	12.5
HGL-3T	75 <sup>3</sup> / <sub>8</sub>	36 <sup>1</sup> / <sub>8</sub>	84 <sup>1</sup> / <sub>4</sub>	1999 (70.60)	—	R-404A	208/230	10.2

\*Field hard wired

**HGL — Electrical Data**

Model	*Refrigeration Load (BTU/h)	A/C Load (BTU/h)	Energy Consumption (kWh/day)
HGL-1BS	3600	7080	23.37
HGL-1B		—	—
HGL-2BS	4650	9150	42.05
HGL-2B		—	—
HGL-3BS	4830	9500	52.49
HGL-3B		—	—

\*Refrigeration load calculated at -30° F evaporation temperature and 105° F condensing temperature

Model	*Refrigeration Load (BTU/h)	A/C Load (BTU/h)	Energy Consumption (kWh/day)
HGL-1TS	3600	7080	23.37
HGL-1T		—	—
HGL-2TS	4650	9150	42.05
HGL-2T		—	—
HGL-3TS	4830	9500	52.49
HGL-3T		—	—

\*Refrigeration load calculated at -30° F evaporation temperature and 105° F condensing temperature

Dimensions shown as inches and (mm).

**HGL-BS**

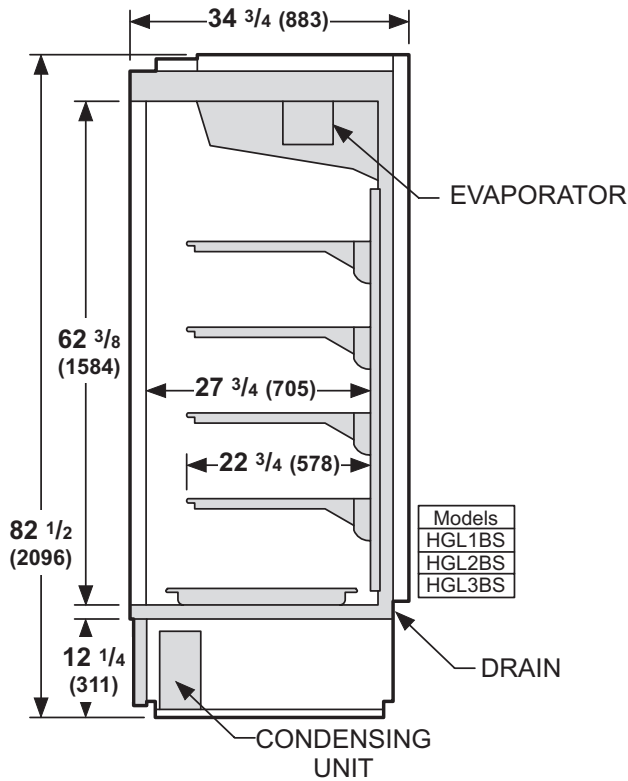

**REFRIGERATION DATA**

	<b>HGL</b>
<b>Thermostat</b>	
<b>Setting CI/CO (°F)</b>	
Position #1	5 / -18
Position #7	-5 / -28
<b>Compressor (hp)</b>	
HGL-1	3/4
HGL-2	1
HGL-3	1 1/2
<b>Condensing Unit</b>	
<b>Capacity</b>	
(Btu/hr at std. rating	
conditions)	
HGL-1	1870
HGL-2	2300
HGL-3	4270
(at 10° F evaporation and	
110° F condensing temperature)	

**HGL-TS**

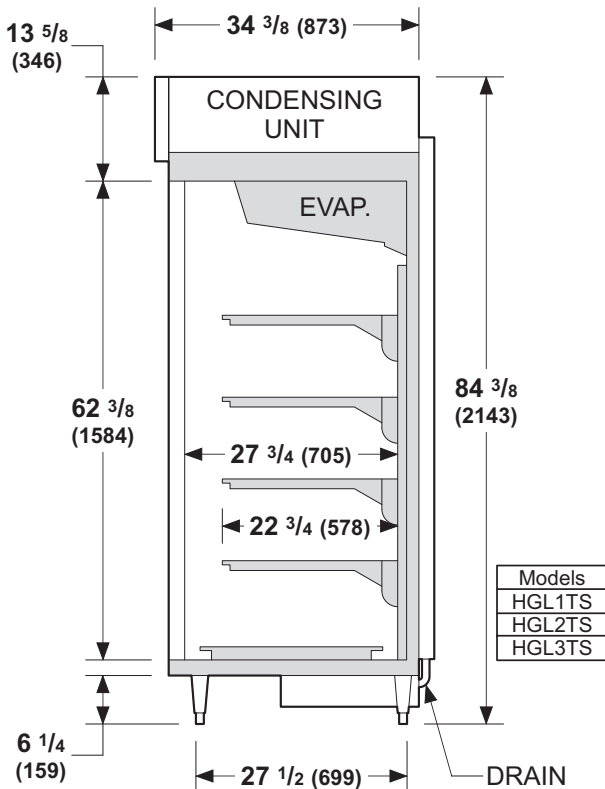

**DEFROST DATA**

	<b>HGL</b>
<b>Frequency (hr)</b>	8
<b>DEFROST TERMINATION</b>	
<b>TEMPERATURE</b>	
<b>Failsafe</b>	50 minutes

**PHYSICAL DATA**

<b>Refrigerant Charge</b>	
HGL-1	35.3 oz (1) kg
HGL-2	37.9 oz (1.074) kg

**Note:** This data is based on store temperature and humidity that does not exceed 75°F and 55% R.H. unless otherwise stated. Schedule defrost at night while lights are off.

**HGL Remote**

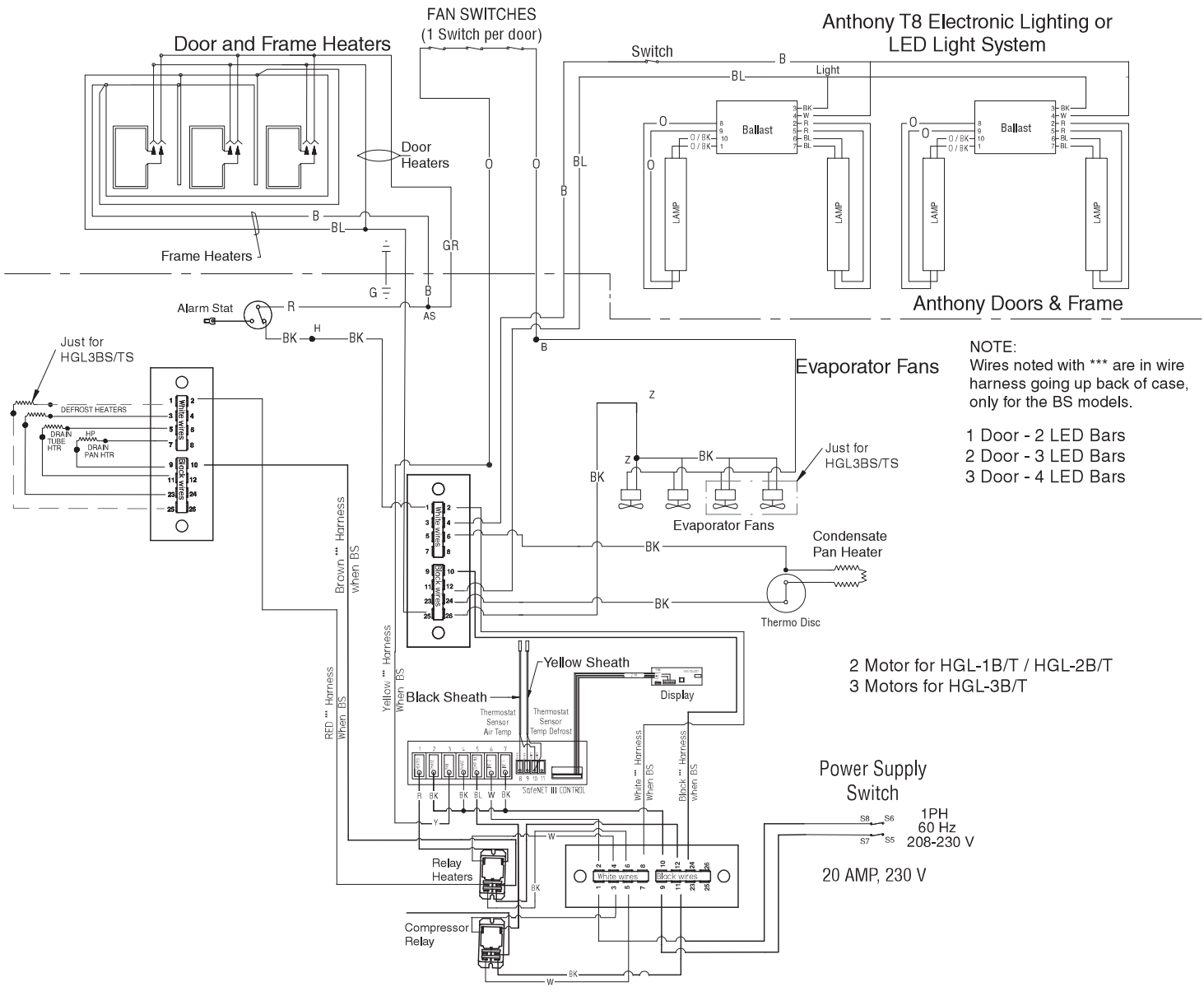

NOTE:  
Wires noted with \*\*\* are in wire harness going up back of case, only for the BS models.

1 Door - 2 LED Bars  
2 Door - 3 LED Bars  
3 Door - 4 LED Bars

2 Motor for HGL-1B/T / HGL-2B/T  
3 Motors for HGL-3B/T

**WARNING:**  
Unplug merchandiser before attempting to make any electrical connections.

**WARNING**

All components must have mechanical ground, and the merchandiser must be grounded.

CIRCLED NUMBERS = PARTS LIST ITEM NUMBERS

R = Red Y = Yellow G = Green BL = Blue BK = Black W = White B = Brown O = Orange GR = Grey

● = 120V POWER ○ = 120V NEUTRAL ⊥ = FIELD GROUND ≡ = CASE GROUND

**HGL Self-Contained**

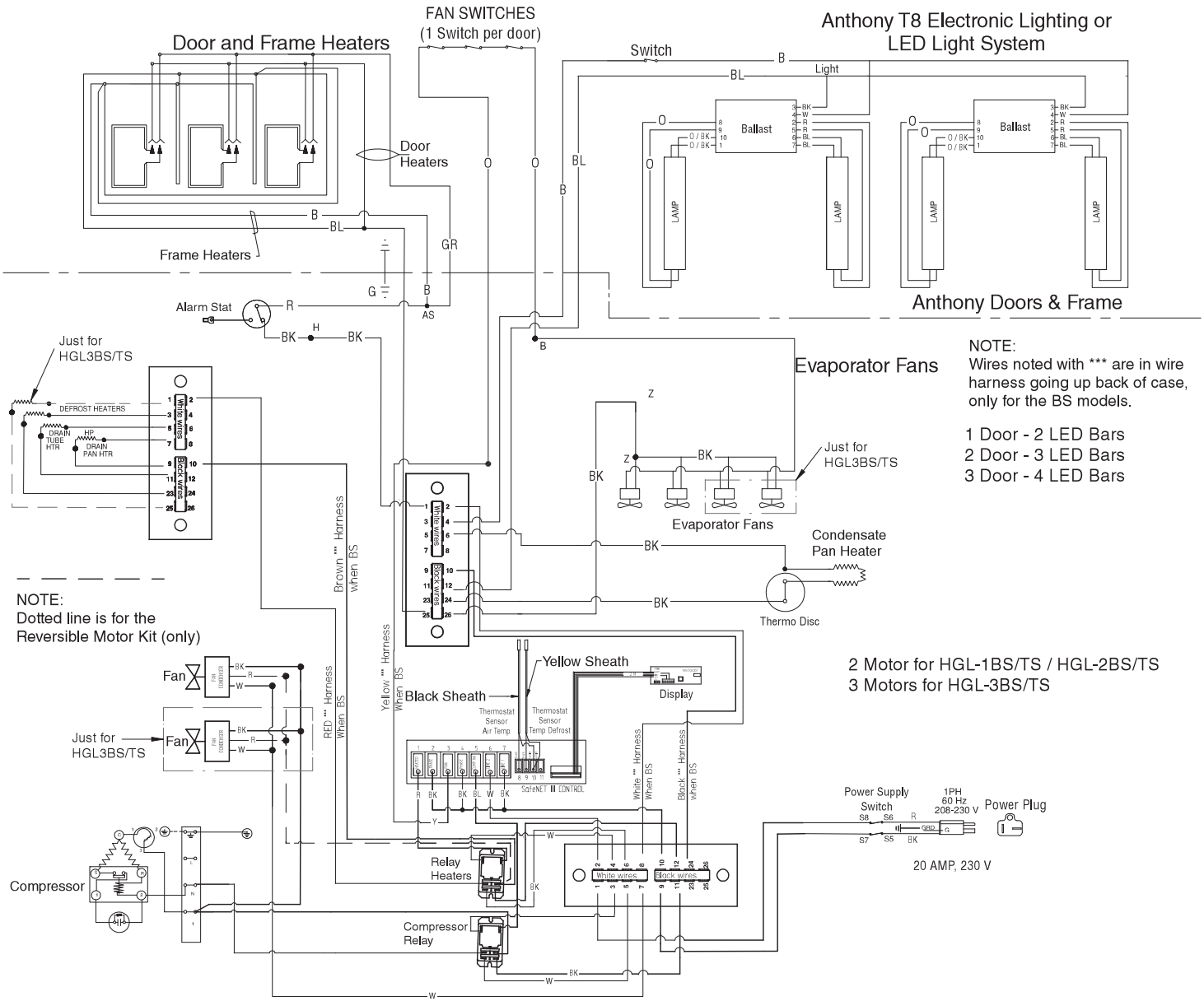

NOTE:  
Wires noted with \*\*\* are in wire harness going up back of case, only for the BS models.

- 1 Door - 2 LED Bars
- 2 Door - 3 LED Bars
- 3 Door - 4 LED Bars

NOTE:  
Dotted line is for the Reversible Motor Kit (only)

- 2 Motor for HGL-1BS/TS / HGL-2BS/TS
- 3 Motors for HGL-3BS/TS

**WARNING:**  
Unplug merchandiser before attempting to make any electrical connections.

**WARNING**

All components must have mechanical ground, and the merchandiser must be grounded.

CIRCLED NUMBERS = PARTS LIST ITEM NUMBERS

R = Red Y = Yellow G = Green BL = Blue BK = Black W = White B = Brown O = Orange GR = Grey

● = 120V POWER ○ = 120V NEUTRAL ⊥ = FIELD GROUND  $\overline{\text{m}}$  = CASE GROUND

A decorative border in blue, consisting of a repeating geometric pattern of interlocking squares and lines, framing the entire page.

# **HUSSMANN<sup>®</sup>**

To obtain warranty information  
or other support, contact your  
Husmann representative.  
Please include the model and  
serial number of the product.

**Husmann Corporation**

12999 St. Charles Rock Road  
Bridgeton, MO 63044-2483  
[www.husmann.com](http://www.husmann.com)

