

HUSSMANN®

SMB

EXCEL

*Service Merchandiser With Curved Glass and
Blower Coil for Meat and Deli - NSF Certified*



IR Ingersoll Rand

Hussmann Excel Service Merchandiser With Curved Glass and Blower Coil for Meat and Deli Applications

HUSSMANN®
EXCEL

SMB - Single Pane Curved Glass Case With Blower Coil for Meat and Deli

Available in 4', 6', 8' and 12' lengths.

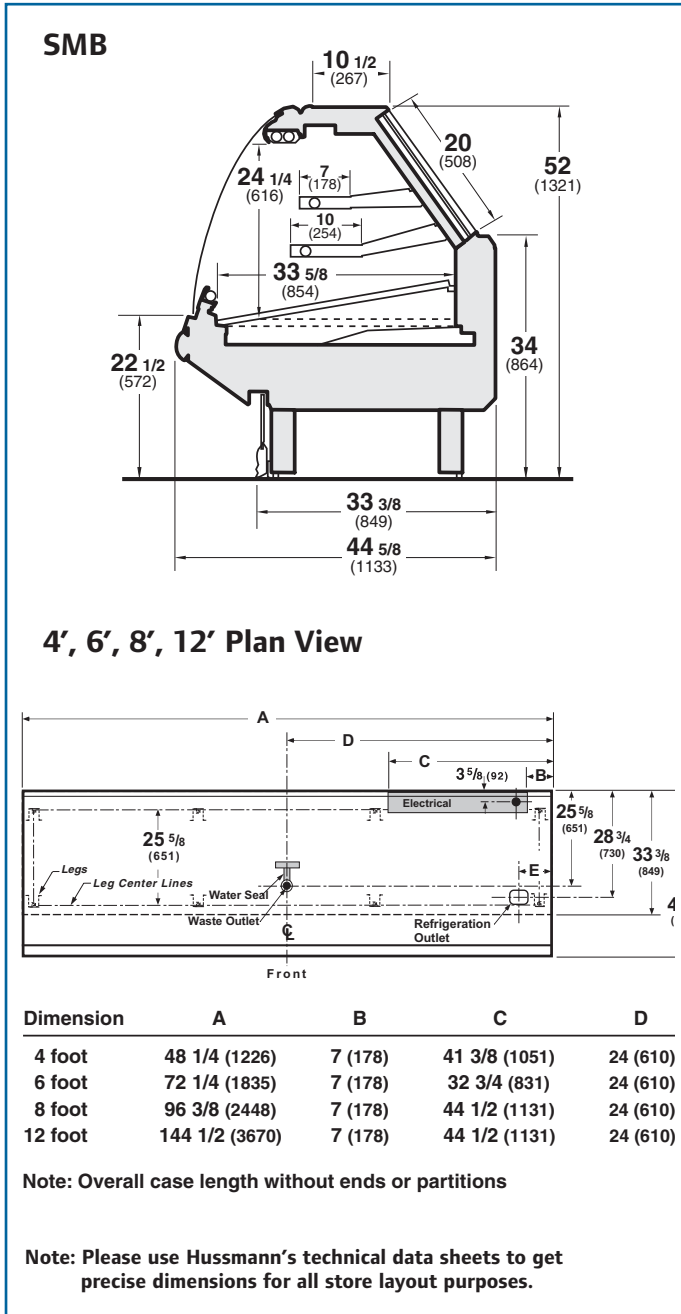

Advanced Impact Design

The SMB and related SM models incorporate advanced features and benefits, including modular coils, superior energy efficiency, modular case design, durable bumper, factory pre-adjusted expansion valves, and seamless polystyrene "bathtub" bottoms for quick, easy cleaning.

Reduced Refrigerant, Fewer Leaks

Patented Hussmann modular coils require 50% to 60% less refrigerant. Also, all return bend solder joints have been eliminated, which greatly reduces the possibility of refrigerant leaks.

Merchandising With Style

One look tells the story. Sleeker, cleaner exterior to enhance product display. Attractive molded end design. Excellent lighting and product visibility for "high impact" merchandising that sells. Up to two lighted mezzanine shelves can be added to increase merchandising capacity. 30°, 45° and 90° inside and outside wedges available.

Easy to Work

Front glass tilts up for easy stocking and cleaning. 10 1/2" stainless flat non-movable top is standard. A large 20" rear door opening has an increased angle to improve reach and ergonomics. Options include mezzanine shelves, display racks, scale stands, thermometers and wrapping boards.

NSF Certified

The SMB has been NSF Certified to ANSI/NSF standard 7.

NOTE: These merchandisers are designed for use in stores when temperature and humidity do not exceed 75°F and 55% R.H.

NOTE: We reserve the right to change or revise specifications and product design in connection with any feature of our products. Such changes do not entitle the buyer to corresponding changes, improvements, additions, or replacements for equipment previously sold or shipped.

Web Site: www.hussmann.com
E-mail: hussmann-marketing@irco.com

IR Ingersoll Rand

Hussmann Corporation
12999 St. Charles Rock Rd.
Bridgeton, MO 63044-2483
(314) 291-2000
(314) 298-4756 Fax